

## 2.5V VOLTAGE REFERENCES

- LOW TEMPERATURE COEFFICIENT
- WIDE OPERATING CURRENT OF 400 $\mu$ A TO 10mA
- 0.2 $\Omega$  DYNAMIC IMPEDANCE
- GUARANTEED TEMPERATURE STABILITY
- FAST TURN-ON

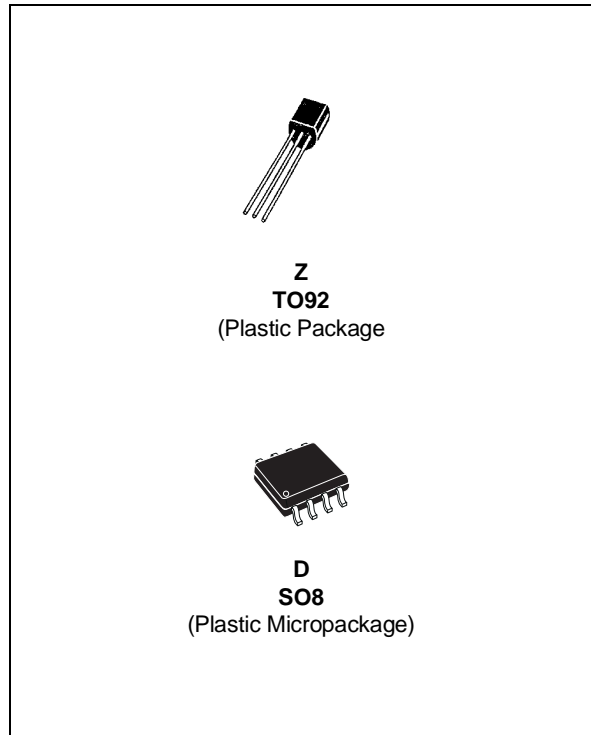

### DESCRIPTION

The LM236 and LM336 are precision 2.5V regulator diodes. These voltage reference monolithic ICs operate like 2.5V zener diodes with a low temperature coefficient and a dynamic impedance of 0.2 $\Omega$ . A third pin enables adjusting the reference voltage and the temperature coefficient.

### ORDER CODES

Part number	Temperature Range	Package	
		Z	D
LM236	-25°C, +85°C	•	•
LM336,B	0°C, +70°C	•	•

### PIN CONNECTIONS

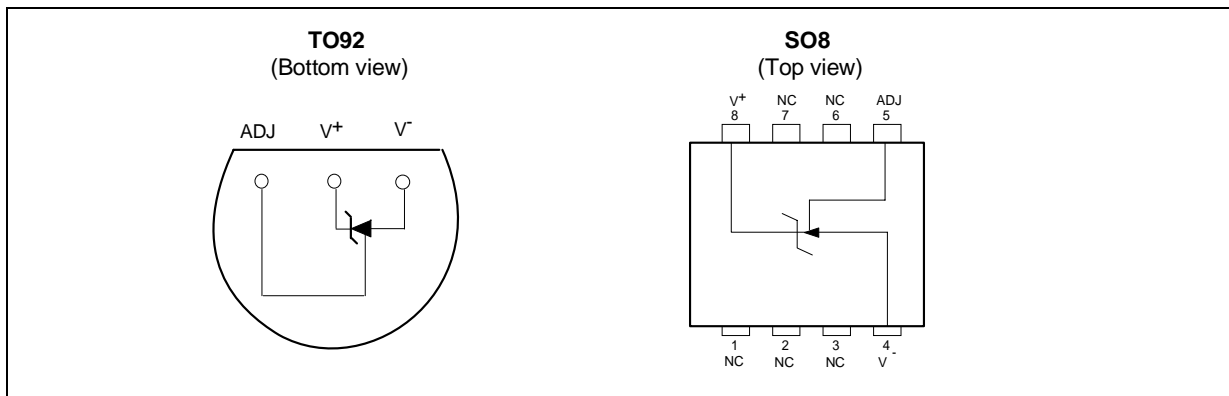

# LM236 - LM336,B

## SCHEMATIC DIAGRAM

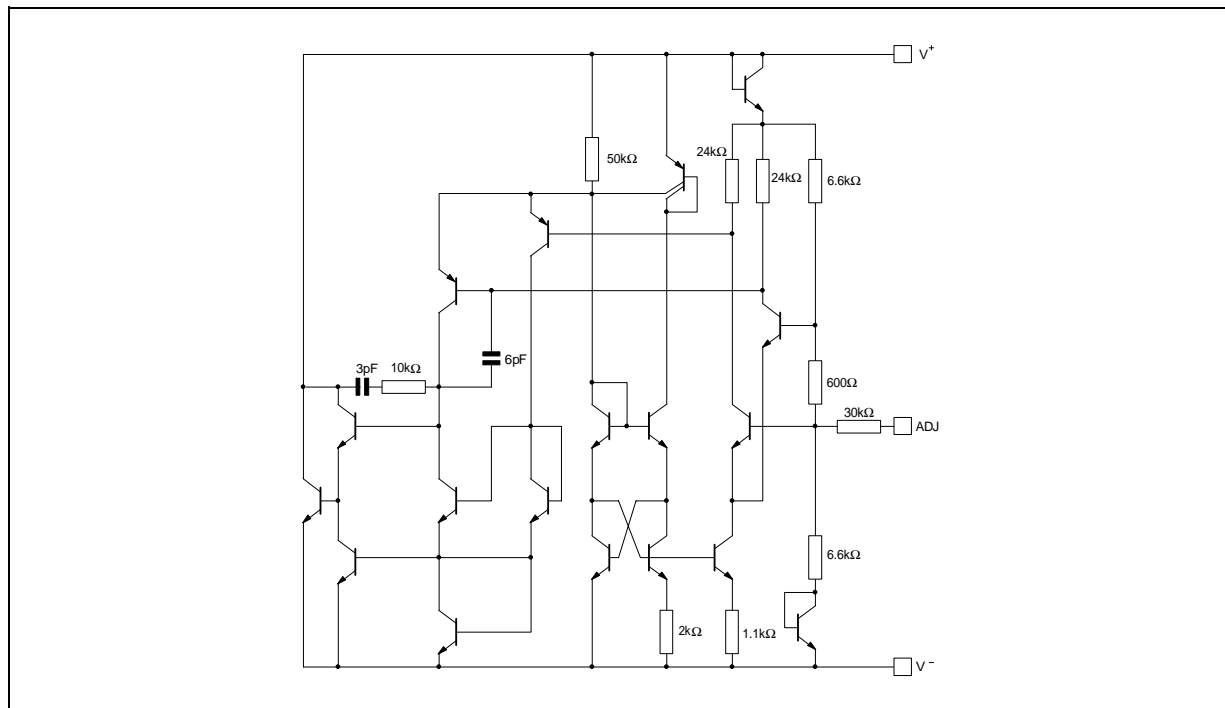

## ABSOLUTE MAXIMUM RATINGS

Symbol	Parameter	LM236	LM336,B	Unit
$I_R$ $I_F$	Current Reverse Forward	15 10	15 10	mA
$T_{oper}$	Operating Free-air Temperature Range	-25 to +85	0 to +70	°C
$T_{stg}$	Storage Temperature Range	-65 to +150		°C

## ELECTRICAL CHARACTERISTICS

**LM236**  $-25^{\circ}\text{C} \leq T_{amb} \leq +85^{\circ}\text{C}$

**LM336,B**  $0^{\circ}\text{C} \leq T_{amb} \leq +70^{\circ}\text{C}$

(unless otherwise specified)

Symbol	Parameter	LM236			LM336,B			Unit
		Min.	Typ.	Max.	Min.	Typ.	Max.	
$V_R$	Reverse Breakdown Voltage ( $T_{amb} = +25^{\circ}\text{C}$ , $I_R = 1\text{mA}$ )  LM236, LM336 LM336B	2.44	2.49	2.54	2.39 2.44	2.49 2.49	2.59 2.54	V
$\Delta V_R$	Reverse Breakdown Voltage Change with Current ( $400\mu\text{A} \leq I_R \leq 10\text{mA}$ ) $T_{amb} = +25^{\circ}\text{C}$ $T_{min.} \leq T_{amb} \leq T_{max.}$		2.6 3	6 10		2.6 3	10 12	mV
$Z_D$	Reverse Dynamic Impedance ( $I_R = 1\text{mA}$ ) $T_{amb} = +25^{\circ}\text{C}$ $T_{min.} \leq T_{amb} \leq T_{max.}$		0.2 0.4	0.6 1		0.2 0.4	1 1.4	$\Omega$
$K_{VT}$	Temperature Stability ( $V_R = 2.49\text{V}$ , $I_R = 1\text{mA}$ )		3.5	9		1.8	6	mV
$K_{VH}$	Long Term Stability ( $T_{amb} = +25^{\circ}\text{C} \pm 0.1^{\circ}\text{C}$ , $I_R = 1\text{mA}$ )		20			20		ppm

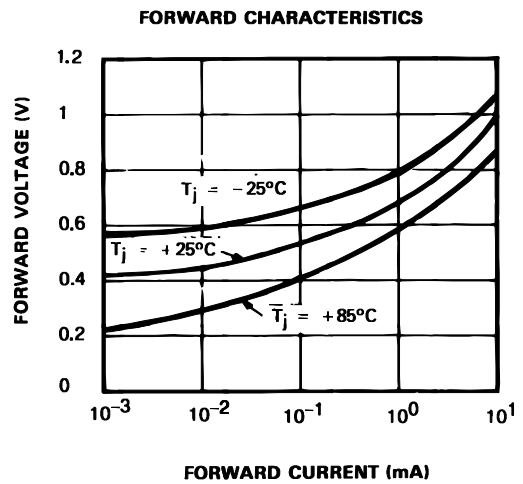
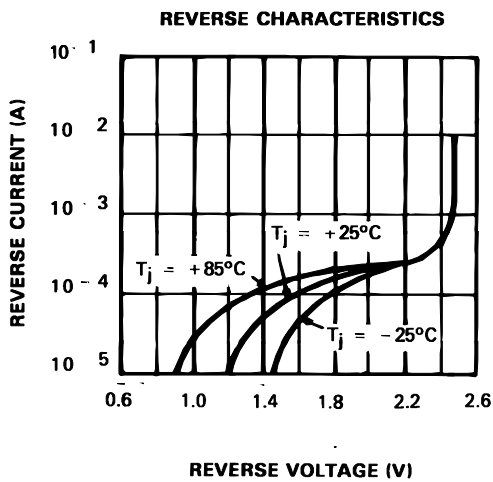
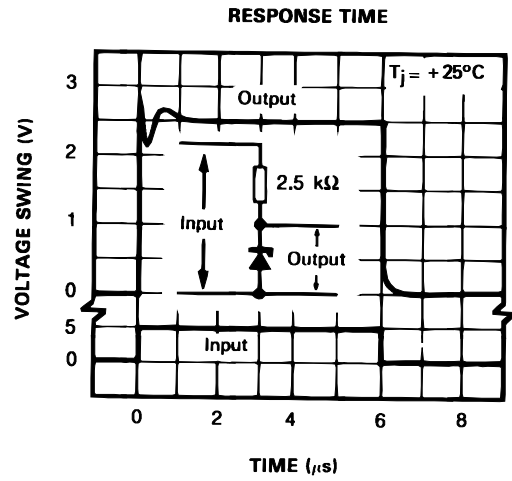
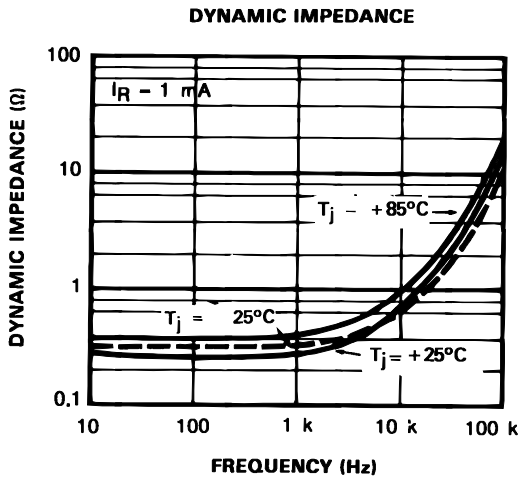
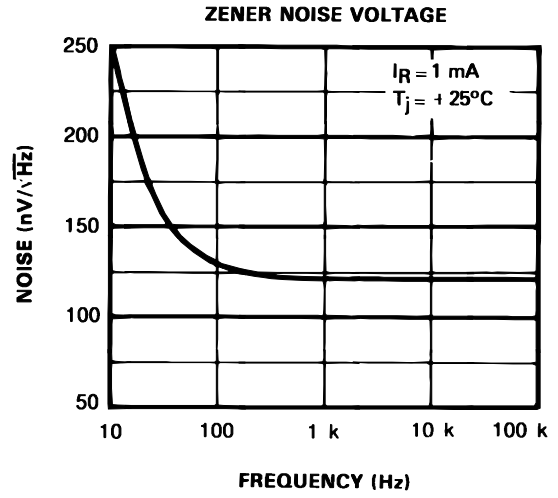
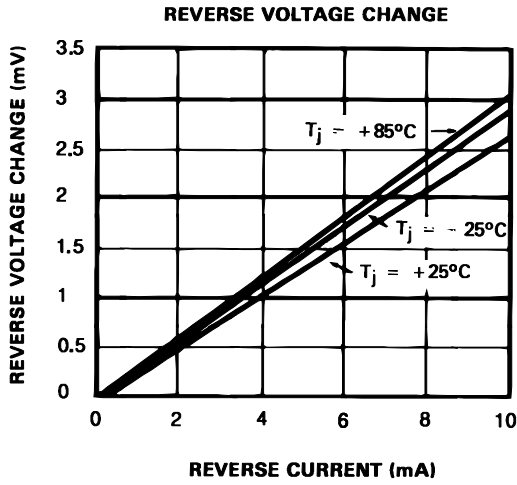

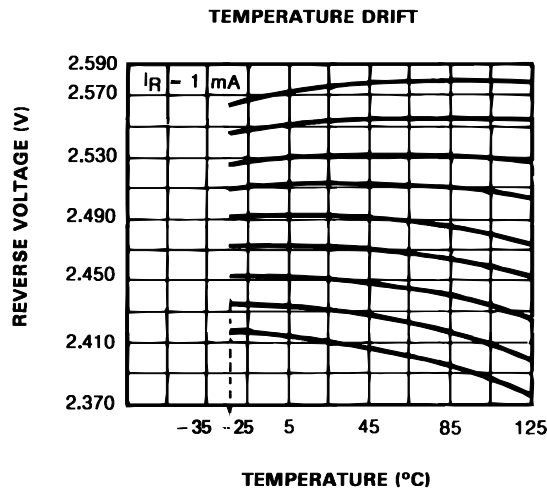

**APPLICATION HINTS**

The LM236, LM336 voltage references are easier to use than zener diodes. Their low impedance and wide current range facilitate biasing in any circuits. Besides, the breakdown voltage or the temperature coefficient can be adjusted so as to optimize the performance of the circuit.

Figure 1 represents a LM336 with a 10kΩ potentiometer to adjust the reverse breakdown voltage can be adjusted without altering the temperature coefficient of the circuit.

**Figure 1 :** The LM336 with Pot for Adjustment of Breakdown Voltage

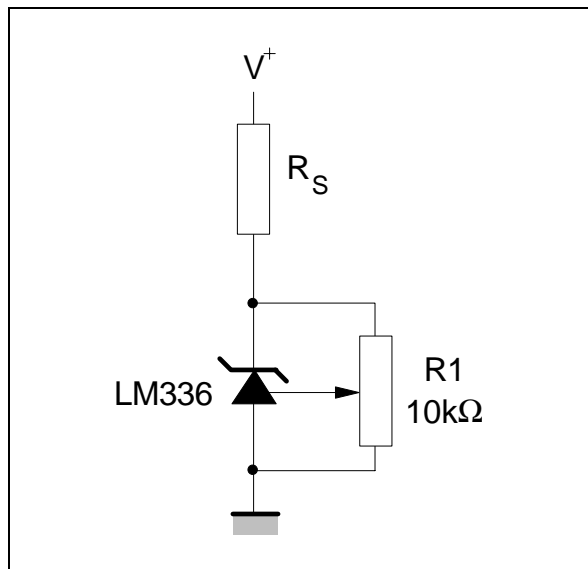

The adjustment range is generally sufficient to adjust the initial tolerance of the circuit and the inaccuracy of the amplifier circuit.

To obtain a lower temperature coefficient two diodes can be connected in series as indicated in Figure 2. When the circuit is adjusted to 2.49V the temperature coefficient is minimized.

For a correct temperature coefficient, the diodes should be at the same ambient temperature as the LM336. The value of  $R_1$  is not critical ( $2-20k\Omega$ ).

**Figure 2 :** Temperature Coefficient Adjustment

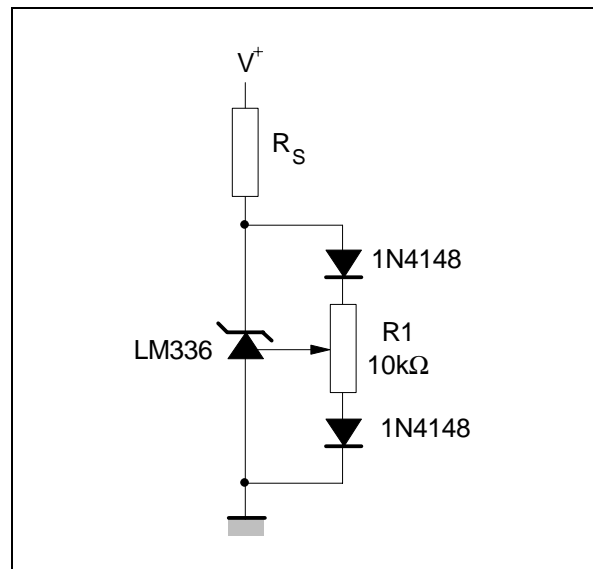

TYPICAL APPLICATIONS

Figure 3 : 2.5V Reference

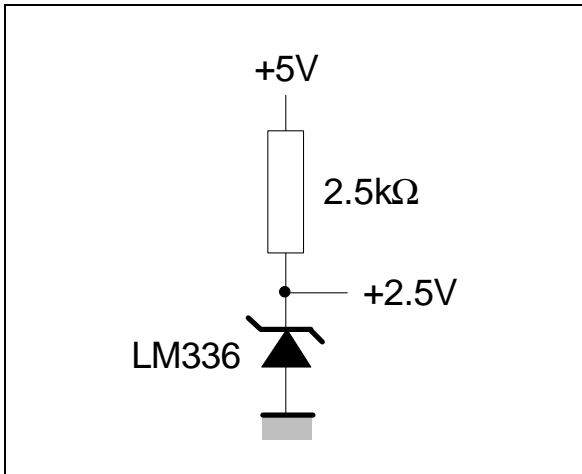

Figure 4 : Wide Input Range Reference

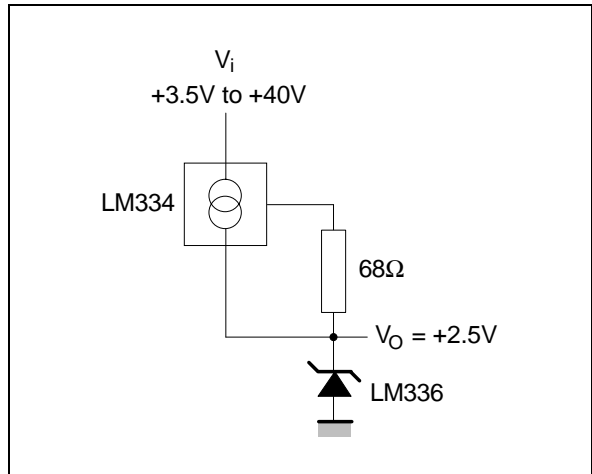

Figure 5 : Precision Power Regulator with Low Temperature Coefficient

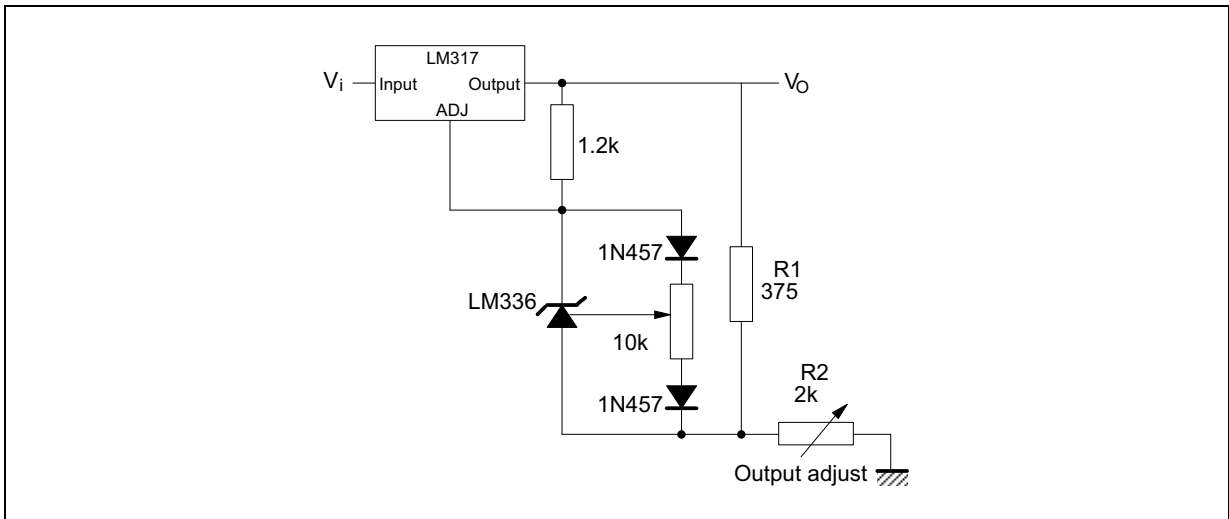

Figure 6 : Adjustable Shunt Regulator

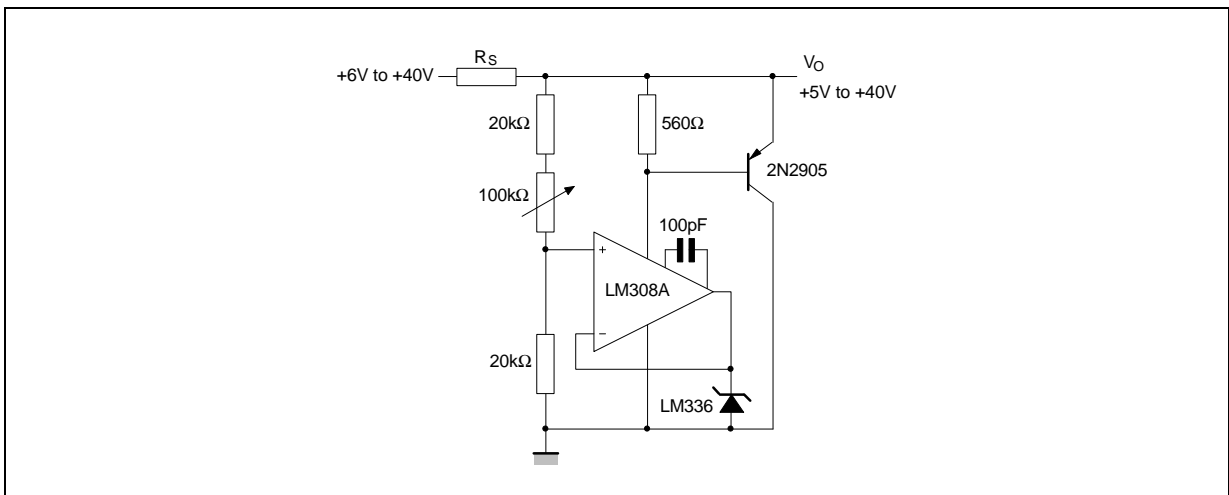

Figure 7 : Linear Ohmmeter

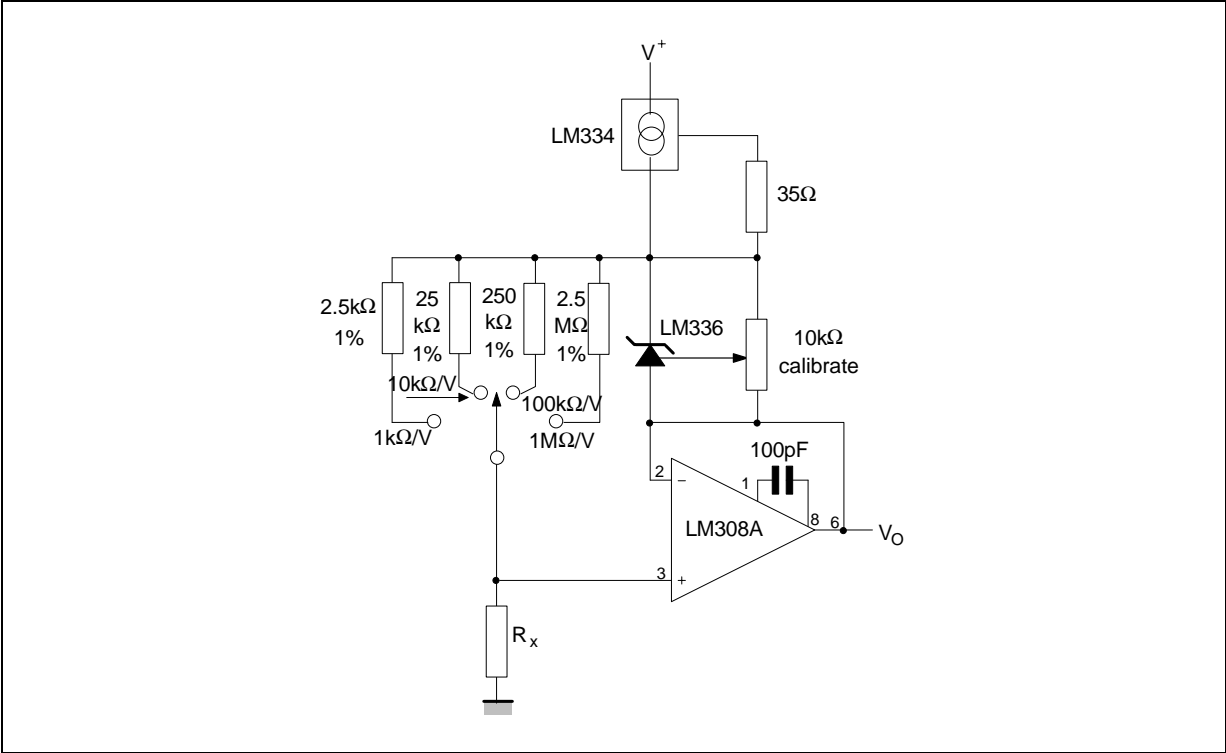

Figure 8 : Bipolar Output Reference

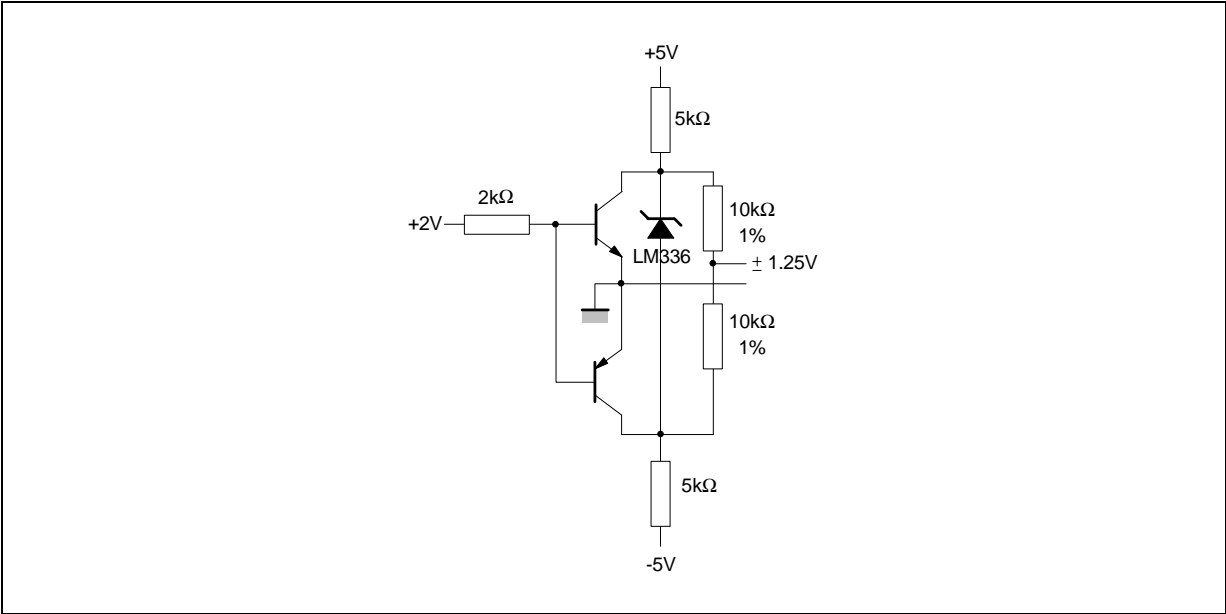

Figure 9 : 5V Buffered Reference

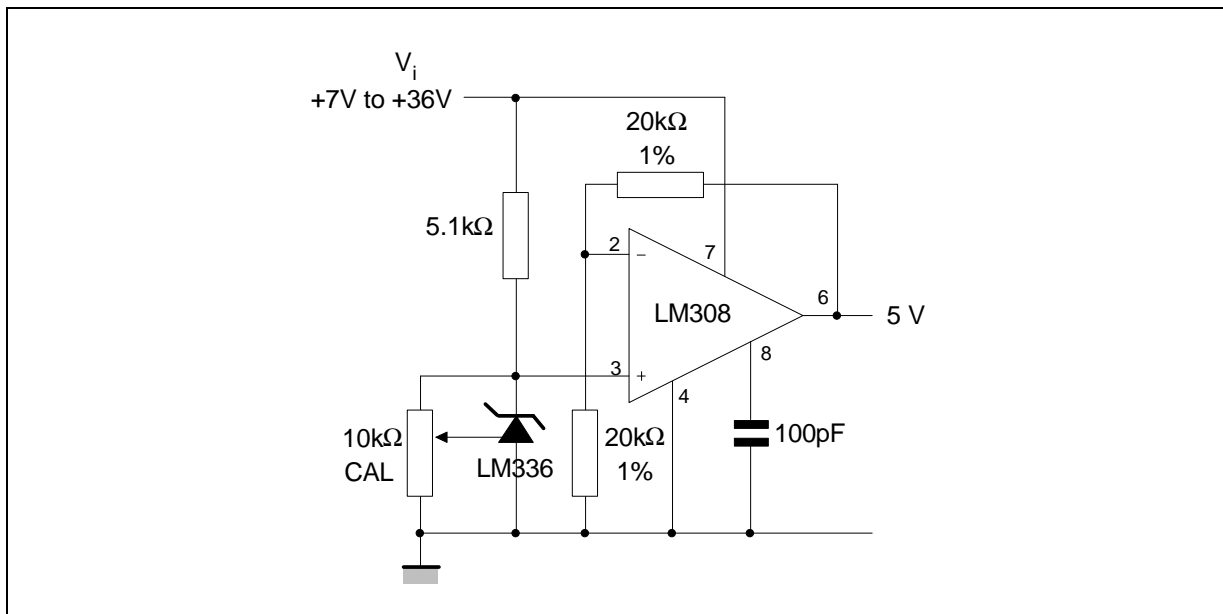
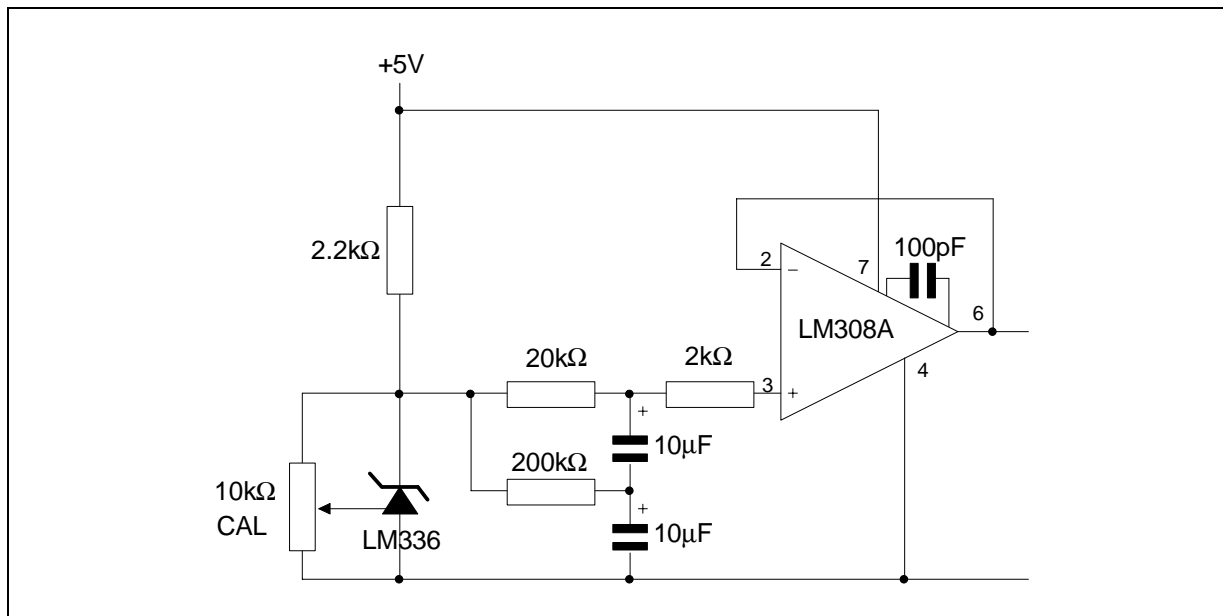
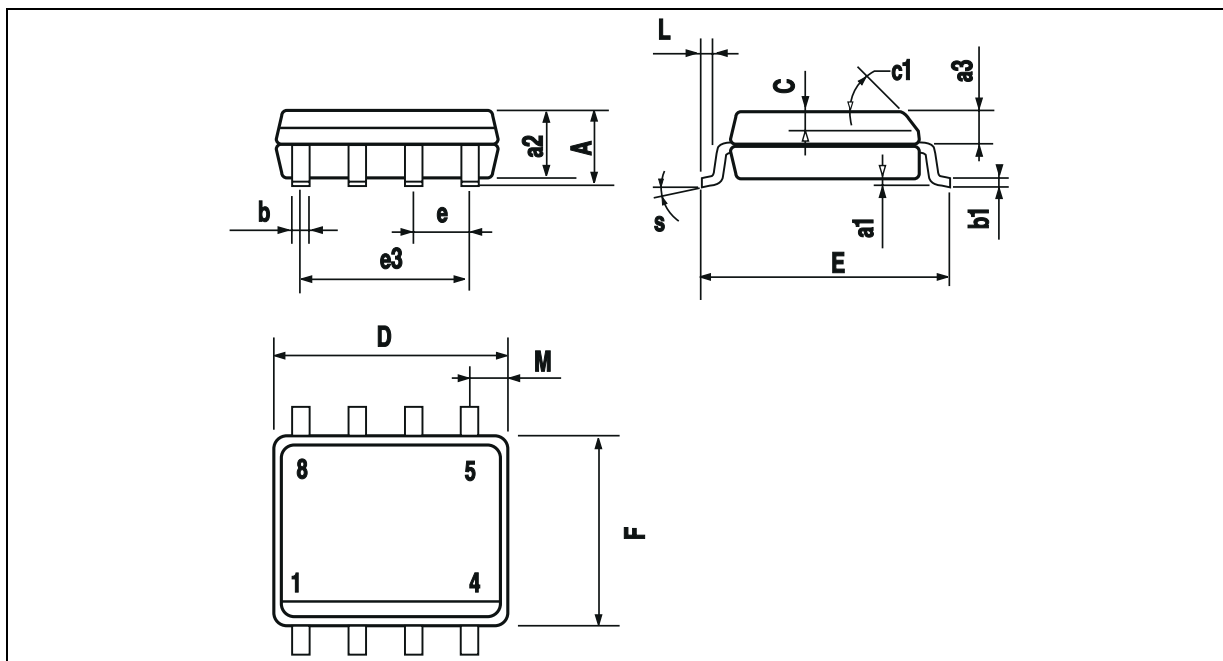

Figure 10 : Low Noise Buffered Reference



**PACKAGE MECHANICAL DATA**  
8 PINS - PLASTIC MICROPACKAGE (SO)



Dimensions	Millimeters			Inches		
	Min.	Typ.	Max.	Min.	Typ.	Max.
A			1.75			0.069
a1	0.1		0.25	0.004		0.010
a2			1.65			0.065
a3	0.65		0.85	0.026		0.033
b	0.35		0.48	0.014		0.019
b1	0.19		0.25	0.007		0.010
C	0.25		0.5	0.010		0.020
c1	45° (typ.)					
D	4.8		5.0	0.189		0.197
E	5.8		6.2	0.228		0.244
e		1.27			0.050	
e3		3.81			0.150	
F	3.8		4.0	0.150		0.157
L	0.4		1.27	0.016		0.050
M			0.6			0.024
S	8° (max.)					

**PACKAGE MECHANICAL DATA**  
**3 PINS - PLASTIC PACKAGE TO92**

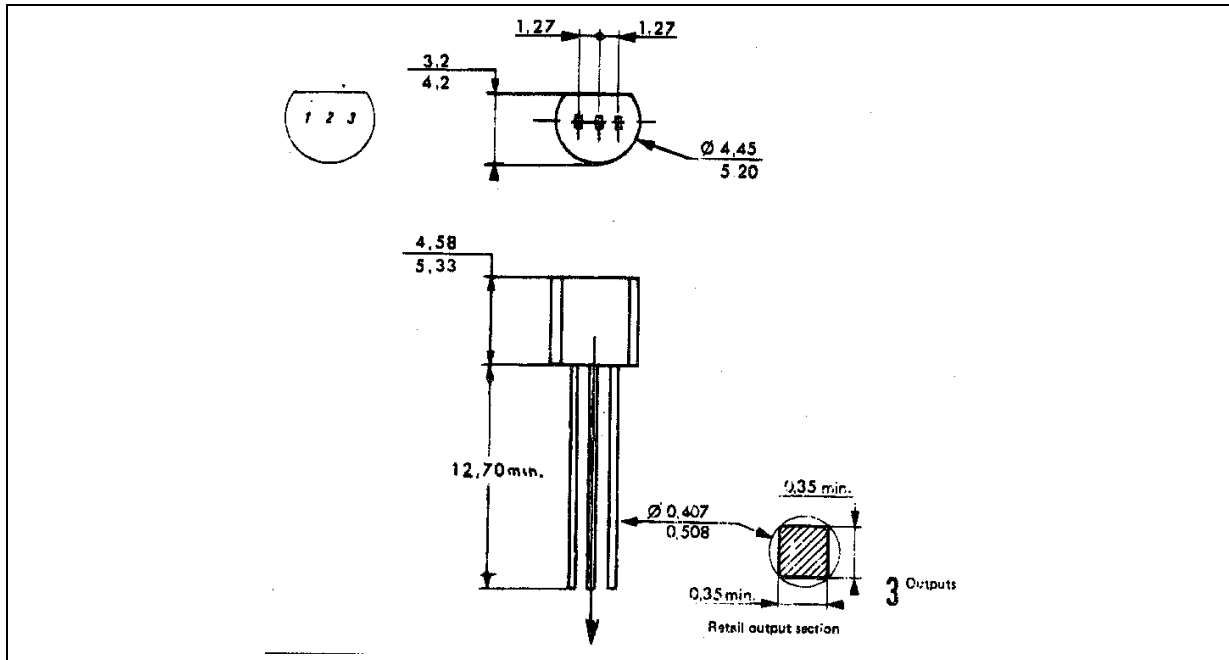

Dimensions	Millimeters			Inches		
	Min.	Typ.	Max.	Min.	Typ.	Max.
L		1.27			0.05	
B	3.2	3.7	4.2	0.126	0.1457	0.1654
O1	4.45	5.00	5.2	0.1752	0.1969	0.2047
C	4.58	5.03	5.33	0.1803	0.198	0.2098
K	12.7			0.5		
O2	0.407	0.5	0.508	0.016	0.0197	0.02
a	0.35			0.0138		

Information furnished is believed to be accurate and reliable. However, SGS-THOMSON Microelectronics assumes no responsibility for the consequences of use of such information nor for any infringement of patents or other rights of third parties which may result from its use. No license is granted by implication or otherwise under any patent or patent rights of SGS-THOMSON Microelectronics. Specification mentioned in this publication are subject to change without notice. This publication supersedes and replaces all information previously supplied. SGS-THOMSON Microelectronics products are not authorized for use as critical components in life support devices or systems without express written approval of SGS-THOMSON Microelectronics.

© 1997 SGS-THOMSON Microelectronics – Printed in Italy – All Rights Reserved

SGS-THOMSON Microelectronics GROUP OF COMPANIES

Australia - Brazil - Canada - China - France - Germany - Hong Kong - Italy - Japan - Korea - Malaysia - Malta - Morocco  
 The Netherlands - Singapore - Spain - Sweden - Switzerland - Taiwan - Thailand - United Kingdom - U.S.A.

This datasheet has been download from:

[www.datasheetcatalog.com](http://www.datasheetcatalog.com)

Datasheets for electronics components.