

MC145170-2

PLL Frequency Synthesizer with Serial Interface

The new MC145170-2 is pin-for-pin compatible with the MC145170-1. A comparison of the two parts is shown in the table below. The MC145170-2 is recommended for new designs and has a more robust power-on reset (POR) circuit that is more responsive to momentary power supply interruptions. The two devices are actually the same chip with mask options for the POR circuit. The more robust POR circuit draws approximately 20 μ A additional supply current. Note that the maximum specification of 100 μ A quiescent supply current has not changed.

The MC145170-2 is a single-chip synthesizer capable of direct usage in the MF, HF, and VHF bands. A special architecture makes this PLL easy to program. Either a bit- or byte-oriented format may be used. Due to the patented BitGrabber™ registers, no address/steering bits are required for *random access* of the three registers. Thus, tuning can be accomplished via a 2-byte serial transfer to the 16-bit N register.

The device features fully programmable R and N counters, an amplifier at the f_{in} pin, on-chip support of an external crystal, a programmable reference output, and both single- and double-ended phase detectors with linear transfer functions (no dead zones). A configuration (C) register allows the part to be configured to meet various applications. A patented feature allows the C register to shut off unused outputs, thereby minimizing noise and interference.

In order to reduce lock times and prevent erroneous data from being loaded into the counters, a patented jam-load feature is included. Whenever a new divide ratio is loaded into the N register, both the N and R counters are jam-loaded with their respective values and begin counting down together. The phase detectors are also initialized during the jam load.

- Operating Voltage Range: 2.7 to 5.5 V
- Maximum Operating Frequency:
185 MHz @ $V_{in} = 500$ mVpp, 4.5 V Minimum Supply
100 MHz @ $V_{in} = 500$ mVpp, 3.0 V Minimum Supply
- Operating Supply Current:
0.6 mA @ 3.0 V, 30 MHz
1.5 mA @ 3.0 V, 100 MHz
3.0 mA @ 5.0 V, 50 MHz
5.8 mA @ 5.0 V, 185 MHz
- Operating Temperature Range: -40 to 85°C
- R Counter Division Range: 1 and 5 to 32,767
- N Counter Division Range: 40 to 65,535
- Direct Interface to Motorola SPI Serial Data Port
- See Application Notes AN1207/D and AN1671/D
- See web site *mot-sps.com* for MC145170 control software. Select in order, Products, Wireless Semiconductor, Download, then PLL Demo Software. Choose PLLGEN.EXE.

BitGrabber is a trademark of Motorola Inc.

COMPARISON OF THE PLL FREQUENCY SYNTHESIZERS

Parameter	MC145170-2	MC145170-1
Minimum Supply Voltage	2.7 V	2.5 V
Maximum Input Current, f_{in}	150 μ A	120 μ A
Dynamic Characteristics, f_{in} (Figure 23)	Unchanged	-
Power-On Reset Circuit	Improved	-

CMOS PLL FREQUENCY SYNTHESIZER WITH SERIAL INTERFACE

SEMICONDUCTOR TECHNICAL DATA

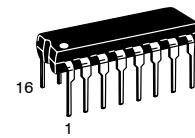

P SUFFIX
PLASTIC PACKAGE
CASE 648

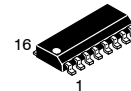

D SUFFIX
PLASTIC PACKAGE
CASE 751B
(SOG-16)

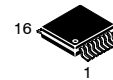

DT SUFFIX
PLASTIC PACKAGE
CASE 948C
(TSSOP-16)

PIN CONNECTIONS

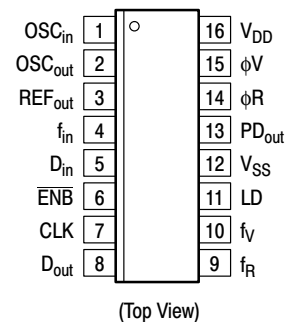

ORDERING INFORMATION

Device	Operating Temp Range	Package
MC145170P2	$T_A = -40$ to 85°C	Plastic DIP
MC145170D2		SOG-16
MC145170DT2		TSSOP-16

MC145170-2 BLOCK DIAGRAM

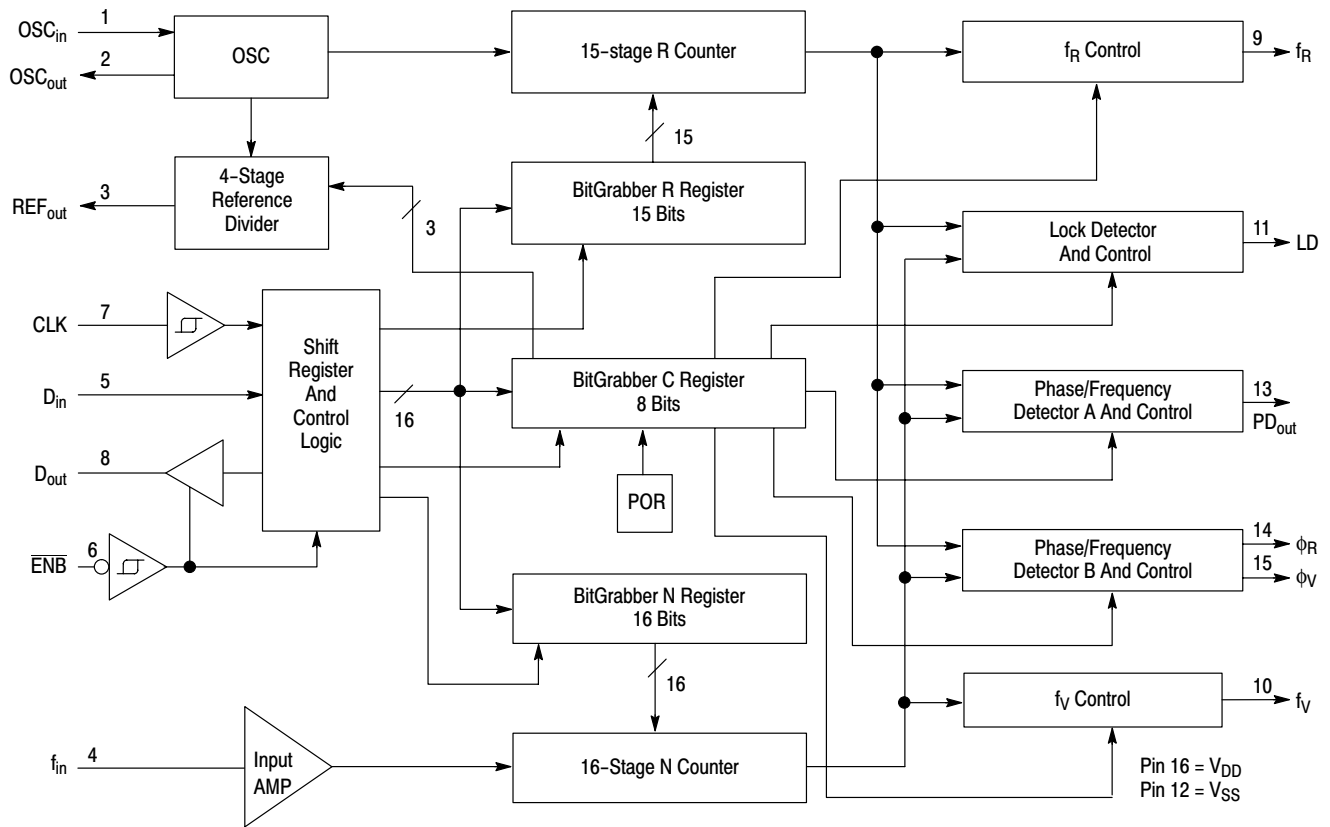

This device contains 4,800 active transistors.

MAXIMUM RATINGS (Voltages Referenced to V_{SS})

Parameter	Symbol	Value	Unit
DC Supply Voltage	V_{DD}	-0.5 to 5.5	V
DC Input Voltage	V_{in}	-0.5 to $V_{DD} + 0.5$	V
DC Output Voltage	V_{out}	-0.5 to $V_{DD} + 0.5$	V
DC Input Current, per Pin	I_{in}	± 10	mA
DC Output Current, per Pin	I_{out}	± 20	mA
DC Supply Current, V_{DD} and V_{SS} Pins	I_{DD}	± 30	mA
Power Dissipation, per Package	P_D	300	mW
Storage Temperature	T_{stg}	-65 to 150	$^{\circ}C$
Lead Temperature, 1 mm from Case for 10 seconds	T_L	260	$^{\circ}C$

NOTES: 1. Maximum Ratings are those values beyond which damage to the device may occur. Functional operation should be restricted to the limits in the Electrical Characteristics tables or Pin Descriptions section.
2. ESD data available upon request.

This device contains protection circuitry to guard against damage due to high static voltages or electric fields. However, precautions must be taken to avoid applications of any voltage higher than maximum rated voltages to this high-impedance circuit. For proper operation, V_{in} and V_{out} should be constrained to the range $V_{SS} \leq (V_{in} \text{ or } V_{out}) \leq V_{DD}$.

Unused inputs must always be tied to an appropriate logic voltage level (e.g., either V_{SS} or V_{DD}). Unused outputs must be left open.

MC145170-2

ELECTRICAL CHARACTERISTICS (Voltages Referenced to V_{SS} , $T_A = -40$ to 85°C)

Parameter	Test Condition	Symbol	V_{DD} V	Guaranteed Limit	Unit
Power Supply Voltage Range		V_{DD}	–	2.7 to 5.5	V
Maximum Low-Level Input Voltage [Note 1] (D_{in} , CLK, ENB, f_{in})	dc Coupling to f_{in}	V_{IL}	2.7 4.5 5.5	0.54 1.35 1.65	V
Minimum High-Level Input Voltage [Note 1] (D_{in} , CLK, ENB, f_{in})	dc Coupling to f_{in}	V_{IH}	2.7 4.5 5.5	2.16 3.15 3.85	V
Minimum Hysteresis Voltage (CLK, ENB)		V_{Hys}	2.7 5.5	0.15 0.20	V
Maximum Low-Level Output Voltage (Any Output)	$I_{out} = 20 \mu\text{A}$	V_{OL}	2.7 5.5	0.1 0.1	V
Minimum High-Level Output Voltage (Any Output)	$I_{out} = -20 \mu\text{A}$	V_{OH}	2.7 5.5	2.6 5.4	V
Minimum Low-Level Output Current (PD_{out} , REF_{out} , f_R , f_V , LD, ϕ_R , ϕ_V)	$V_{out} = 0.3 \text{ V}$ $V_{out} = 0.4 \text{ V}$ $V_{out} = 0.5 \text{ V}$	I_{OL}	2.7 4.5 5.5	0.12 0.36 0.36	mA
Minimum High-Level Output Current (PD_{out} , REF_{out} , f_R , f_V , LD, ϕ_R , ϕ_V)	$V_{out} = 2.4 \text{ V}$ $V_{out} = 4.1 \text{ V}$ $V_{out} = 5.0 \text{ V}$	I_{OH}	2.7 4.5 5.5	-0.12 -0.36 -0.36	mA
Minimum Low-Level Output Current (D_{out})	$V_{out} = 0.4 \text{ V}$	I_{OL}	4.5	1.6	mA
Minimum High-Level Output Current (D_{out})	$V_{out} = 4.1 \text{ V}$	I_{OH}	4.5	-1.6	mA
Maximum Input Leakage Current (D_{in} , CLK, ENB, OSC_{in})	$V_{in} = V_{DD}$ or V_{SS}	I_{in}	5.5	± 1.0	μA
Maximum Input Current (f_{in})	$V_{in} = V_{DD}$ or V_{SS}	I_{in}	5.5	± 150	μA
Maximum Output Leakage Current (PD_{out}) (D_{out})	$V_{in} = V_{DD}$ or V_{SS} , Output in High-Impedance State	I_{OZ}	5.5 5.5	± 100 ± 5.0	nA μA
Maximum Quiescent Supply Current	$V_{in} = V_{DD}$ or V_{SS} ; Outputs Open; Excluding f_{in} Amp Input Current Component	I_{DD}	5.5	100	μA
Maximum Operating Supply Current	$f_{in} = 500 \text{ mVpp}$; $OSC_{in} = 1.0 \text{ MHz @ } 1.0 \text{ Vpp}$; LD, f_R , f_V , $REF_{out} = \text{Inactive and No Connect}$; OSC_{out} , ϕ_V , ϕ_R , $PD_{out} = \text{No Connect}$; D_{in} , ENB, CLK = V_{DD} or V_{SS}	I_{dd}	–	[Note 2]	mA

NOTES: 1. When dc coupling to the OSC_{in} pin is used, the pin must be driven rail-to-rail. In this case, OSC_{out} should be floated.

2. The nominal values at 3.0 V are 0.6 mA @ 30 MHz, and 1.5 mA @ 100 MHz. The nominal values at 5.0 V are 3.0 mA @ 50 MHz, and 5.8 mA @ 185 MHz. These are not guaranteed limits.

MC145170-2

AC INTERFACE CHARACTERISTICS ($T_A = -40$ to 85°C , $C_L = 50$ pF, Input $t_r = t_f = 10$ ns, unless otherwise noted.)

Parameter	Symbol	Figure No.	V _{DD} V	Guaranteed Limit	Unit
Serial Data Clock Frequency (Note: Refer to Clock t_w Below)	f_{clk}	1	2.7 4.5 5.5	dc to 3.0 dc to 4.0 dc to 4.0	MHz
Maximum Propagation Delay, CLK to D _{out}	$t_{\text{PLH}}, t_{\text{PHL}}$	1, 5	2.7 4.5 5.5	150 85 85	ns
Maximum Disable Time, D _{out} Active to High Impedance	$t_{\text{PLZ}}, t_{\text{PHZ}}$	2, 6	2.7 4.5 5.5	300 200 200	ns
Access Time, D _{out} High Impedance to Active	$t_{\text{PZL}}, t_{\text{PZH}}$	2, 6	2.7 4.5 5.5	0 to 200 0 to 100 0 to 100	ns
Maximum Output Transition Time, D _{out} CL = 50 pF CL = 200 pF	$t_{\text{TLH}}, t_{\text{THL}}$	1, 5	2.7 4.5 5.5	150 50 50	ns
			2.7 4.5 5.5	900 150 150	ns
Maximum Input Capacitance – D _{in} , $\overline{\text{ENB}}$, CLK	C_{in}		–	10	pF
Maximum Output Capacitance – D _{out}	C_{out}		–	10	pF

TIMING REQUIREMENTS ($T_A = -40$ to 85°C , Input $t_r = t_f = 10$ ns, unless otherwise noted.)

Parameter	Symbol	Figure No.	V _{DD} V	Guaranteed Limit	Unit
Minimum Setup and Hold Times, D _{in} vs CLK	$t_{\text{su}}, t_{\text{h}}$	3	2.7 4.5 5.5	55 40 40	ns
Minimum Setup, Hold, and Recovery Times, $\overline{\text{ENB}}$ vs CLK	$t_{\text{su}}, t_{\text{h}}, t_{\text{rec}}$	4	2.7 4.5 5.5	135 100 100	ns
Minimum Inactive-High Pulse Width, ENB	$t_{\text{w(H)}}$	4	2.7 4.5 5.5	400 300 300	ns
Minimum Pulse Width, CLK	t_w	1	2.7 4.5 5.5	166 125 125	ns
Maximum Input Rise and Fall Times, CLK	t_r, t_f	1	2.7 4.5 5.5	100 100 100	μs

MC145170-2

SWITCHING WAVEFORMS

Figure 1.

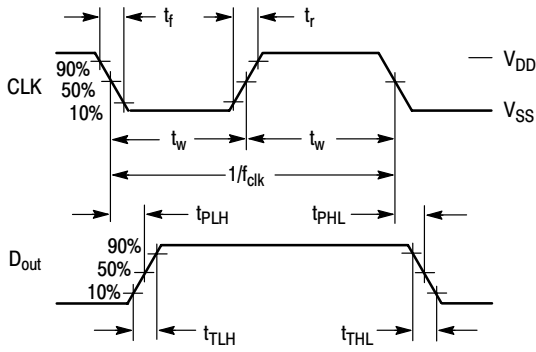

Figure 2.

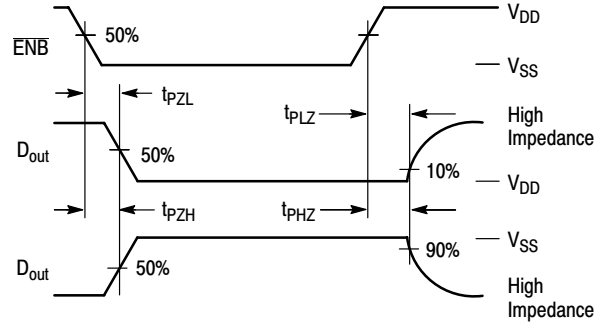

Figure 3.

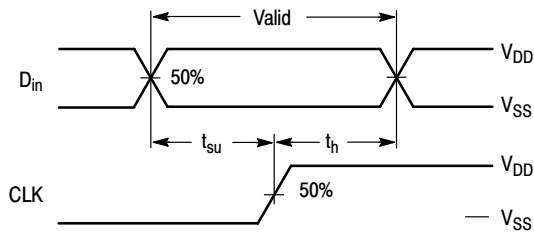

Figure 4.

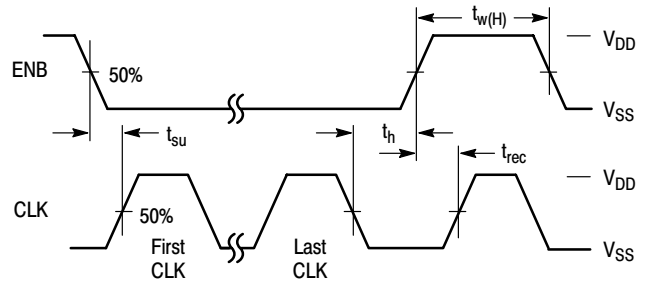
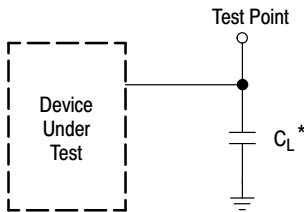
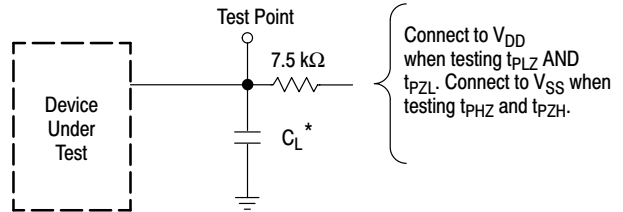

Figure 5. Test Circuit



* Includes all probe and fixture capacitance.

Figure 6. Test Circuit



* Includes all probe and fixture capacitance.

Connect to V_{DD} when testing t_{PLZ} AND t_{PZL} . Connect to V_{SS} when testing t_{PHZ} and t_{PZH} .

MC145170–2

LOOP SPECIFICATIONS ($T_A = -40$ to 85°C)

Parameter	Test Condition	Symbol	Figure No.	V _{DD} V	Guaranteed Range		Unit
					Min	Max	
Input Frequency, f_{in} [Note]	$V_{in} \geq 500$ mVpp Sine Wave, N Counter Set to Divide Ratio Such that $f_V \leq 2.0$ MHz	f	7	2.7 3.0 4.5 5.5	5.0 5.0 25 45	80 100 185 185	MHz
Input Frequency, OSC _{in} Externally Driven with ac-coupled Signal	$V_{in} \geq 1.0$ V _{pp} Sine Wave, OSC _{out} = No Connect, R Counter Set to Divide Ratio Such that $f_R \leq 2$ MHz	f	8a	2.7 3.0 4.5 5.5	1.0* 1.0* 1.0* 1.0*	22 25 30 35	MHz
Crystal Frequency, OSC _{in} and OSC _{out}	$C_1 \leq 30$ pF $C_2 \leq 30$ pF Includes Stray Capacitance	f_{XTAL}	9	2.7 3.0 4.5 5.5	2.0 2.0 2.0 2.0	12 12 15 15	MHz
Output Frequency, REF _{out}	$C_L = 30$ pF	f_{out}	10, 12	2.7 4.5 5.5	dc dc dc	– 10 10	MHz
Operating Frequency of the Phase Detectors		f		2.7 4.5 5.5	dc dc dc	– 2.0 2.0	MHz
Output Pulse Width, ϕ_R , ϕ_V , and LD	f_R in Phase with f_V $C_L = 50$ pF	t_w	11, 12	2.7 4.5 5.5	– 20 16	– 100 90	ns
Output Transition Times, ϕ_R , ϕ_V , LD, f_R , and f_V	$C_L = 50$ pF	t_{TLH} , t_{THL}	11, 12	2.7 4.5 5.5	– – –	– 65 60	ns
Input Capacitance		C_{in}	– –	– –	– –	7.0 7.0	pF

* IF lower frequency is desired, use wave shaping or higher amplitude sinusoidal signal in ac-coupled case. Also, see Figure 22 for dc coupling.

MC145170-2

Figure 7. Test Circuit, f_{in}

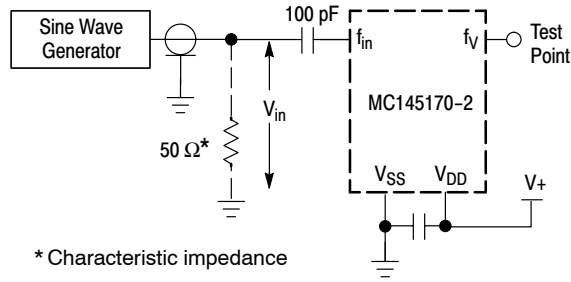

Figure 8.

Figure 8a. Test Circuit, OSC Circuit Externally Driven [Note]

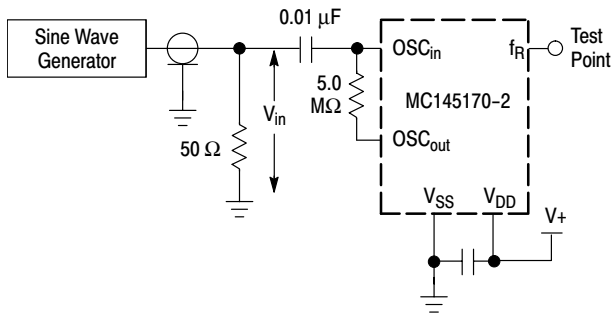

Figure 8b. Circuit to Eliminate Self-Oscillation, OSC Circuit Externally Driven [Note]

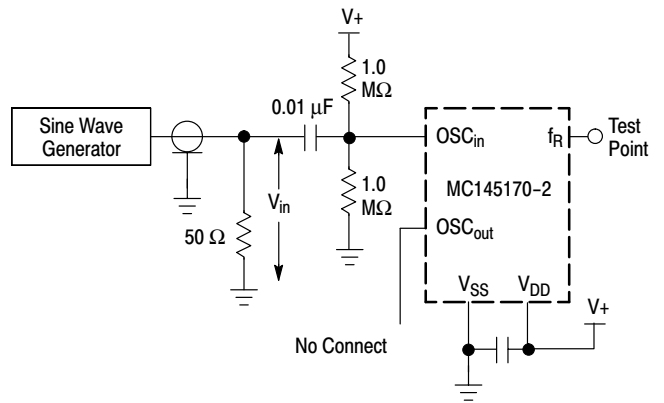

Figure 9. Test Circuit, OSC Circuit with Crystal

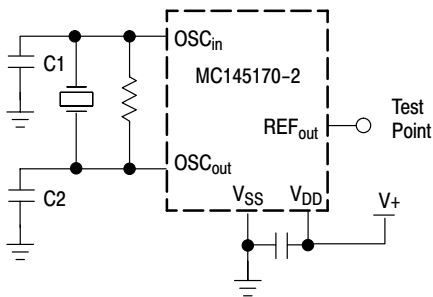

Figure 10. Switching Waveform

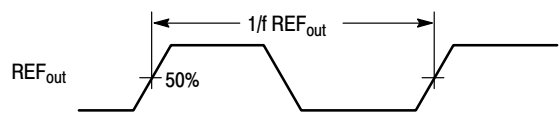

Figure 11. Switching Waveform

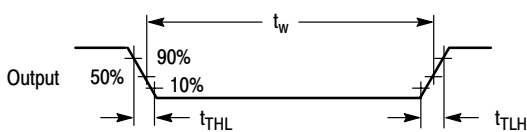
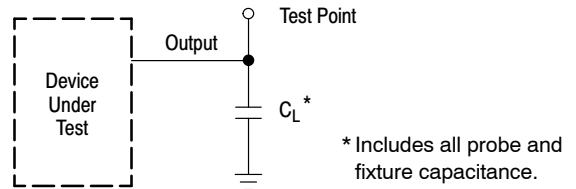

Figure 12. Test Load Circuit



NOTE: Use the circuit of Figure 8b to eliminate self-oscillation of the OSC_{in} pin when the MC145170-2 has power applied with no external signal applied at V_{in}. (Self-oscillation is not harmful to the MC145170-2 and does not damage the IC.)

MC145170–2

PIN DESCRIPTIONS

DIGITAL INTERFACE PINS

D_{in}

Serial Data Input (Pin 5)

The bit stream begins with the most significant bit (MSB) and is shifted in on the low-to-high transition of CLK. The bit pattern is 1 byte (8 bits) long to access the C or configuration register, 2 bytes (16 bits) to access the N register, or 3 bytes (24 bits) to access the R register. Additionally, the R register can be accessed with a 15-bit transfer (see Table 1). An optional pattern which resets the device is shown in Figure 13. The values in the C, N, and R registers do not change during shifting because the transfer of data to the registers is controlled by $\overline{\text{ENB}}$.

The bit stream needs neither address nor steering bits due to the innovative BitGrabber registers. Therefore, all bits in the stream are available to be data for the three registers. Random access of any register is provided (i.e., the registers may be accessed in any sequence). Data is retained in the registers over a supply range of 2.7 to 5.5 V. The formats are shown in Figures 13, 14, 15, and 16.

D_{in} typically switches near 50% of V_{DD} to maximize noise immunity. This input can be directly interfaced to CMOS devices with outputs guaranteed to switch near rail-to-rail. When interfacing to NMOS or TTL devices, either a level shifter (MC74HC14A, MC14504B) or pull-up resistor of 1 to 10 kΩ must be used. Parameters to consider when sizing the resistor are worst-case I_{OL} of the driving device, maximum tolerable power consumption, and maximum data rate.

Table 1. Register Access
(MSBs are shifted in first, C0, N0, and R0 are the LSBs)

Number of Clocks	Accessed Register	Bit Nomenclature
9 to 13	See Figure 13	(Reset)
8	C Register	C7, C6, C5, . . . , C0
16	N Register	N15, N14, N13, . . . , N0
15 or 24	R Register	R14, R13, R12, . . . , R0
Other Values ≤ 32	None	
Values > 32	See Figures 24 — 31	

CLK

Serial Data Clock Input (Pin 7)

Low-to-high transitions on Clock shift bits available at D_{in}, while high-to-low transitions shift bits from D_{out}. The chip's 16–1/2–stage shift register is static, allowing clock rates down to dc in a continuous or intermittent mode.

Four to eight clock cycles followed by five clock cycles are needed to reset the device; this is optional. Eight clock cycles are required to access the C register. Sixteen clock cycles are needed for the N register. Either 15 or 24 cycles can be used to access the R register (see Table 1 and Figures 13, 14, 15, and 16). For cascaded devices, see Figures 24 to 31.

CLK typically switches near 50% of V_{DD} and has a Schmitt-triggered input buffer. Slow CLK rise and fall times are allowed. See the last paragraph of D_{in} for more information.

NOTE

To guarantee proper operation of the power-on reset (POR) circuit, the CLK pin must be held at the potential of either the V_{SS} or V_{DD} pin during power up. That is, the CLK input should not be floated or toggled while the V_{DD} pin is ramping from 0 to at least 2.7 V. If control of the CLK pin is not practical during power up, the initialization sequence shown in Figure 13 must be used.

$\overline{\text{ENB}}$

Active-Low Enable Input (Pin 6)

This pin is used to activate the serial interface to allow the transfer of data to/from the device. When $\overline{\text{ENB}}$ is in an inactive high state, shifting is inhibited, D_{out} is forced to the high-impedance state, and the port is held in the initialized state. To transfer data to the device, $\overline{\text{ENB}}$ (which must start inactive high) is taken low, a serial transfer is made via D_{in} and CLK, and $\overline{\text{ENB}}$ is taken back high. The low-to-high transition on $\overline{\text{ENB}}$ transfers data to the C, N, or R register depending on the data stream length per Table 1.

NOTE

Transitions on $\overline{\text{ENB}}$ must not be attempted while CLK is high. This puts the device out of synchronization with the microcontroller. Resynchronization occurs when $\overline{\text{ENB}}$ is high and CLK is low.

This input is also Schmitt-triggered and switches near 50% of V_{DD}, thereby minimizing the chance of loading erroneous data into the registers. See the last paragraph of D_{in} for more information.

D_{out}

Three-State Serial Data Output (Pin 8)

Data is transferred out of the 16–1/2–stage shift register through D_{out} on the high-to-low transition of CLK. This output is a No Connect, unless used in one of the manners discussed below.

D_{out} could be fed back to an MCU/MPU to perform a wrap-around test of serial data. This could be part of a system check conducted at power up to test the integrity of the system's processor, PC board traces, solder joints, etc.

The pin could be monitored at an in-line QA test during board manufacturing.

Finally, D_{out} facilitates troubleshooting a system and permits cascading devices.

REFERENCE PINS

OSC_{in}/OSC_{out}

Reference Oscillator Input/Output (Pins 1, 2)

These pins form a reference oscillator when connected to terminals of an external parallel-resonant crystal. Frequency-setting capacitors of appropriate values as recommended by the crystal supplier are connected from each pin to ground (up to a maximum of 30 pF each, including stray capacitance). An external feedback resistor of 1.0 to 5.0 MΩ is connected directly across the pins to ensure linear operation of the amplifier. The required connections for the components are shown in Figure 9.

If desired, an external clock source can be ac coupled to OSC_{in}. A 0.01 μF coupling capacitor is used for measurement purposes and is the minimum size

recommended for applications. An external feedback resistor of approximately 5 M Ω is required across the OSC_{in} and OSC_{out} pins in the ac-coupled case (see Figure 8a or alternate circuit 8b). OSC_{out} is an internal node on the device and should not be used to drive any loads (i.e., OSC_{out} is unbuffered). However, the buffered REF_{out} is available to drive external loads.

The external signal level must be at least 1 V p-p; the maximum frequencies are given in the **Loop Specifications** table. These maximum frequencies apply for R Counter divide ratios as indicated in the table. For very small ratios, the maximum frequency is limited to the divide ratio times 2 MHz. (Reason: the phase/frequency detectors are limited to a maximum input frequency of 2 MHz.)

If an external source is available which swings virtually rail-to-rail (V_{DD} to V_{SS}), then dc coupling can be used. In the dc-coupled case, no external feedback resistor is needed. OSC_{out} must be a No Connect to avoid loading an internal node on the device, as noted above. *For frequencies below 1 MHz, dc coupling must be used.* The R counter is a static counter and may be operated down to dc. However, wave shaping by a CMOS buffer may be required to ensure fast rise and fall times into the OSC_{in} pin. See Figure 22.

Each rising edge on the OSC_{in} pin causes the R counter to decrement by one.

REF_{out}

Reference Frequency Output (Pin 3)

This output is the buffered output of the crystal-generated reference frequency or externally provided reference source. This output may be enabled, disabled, or scaled via bits in the C register (see Figure 14).

REF_{out} can be used to drive a microprocessor clock input, thereby saving a crystal. Upon power up, the on-chip power-on-initialize circuit forces REF_{out} to the OSC_{in} divided-by-8 mode.

REF_{out} is capable of operation to 10 MHz; see the **Loop Specifications** table. Therefore, divide values for the reference divider are restricted to two or higher for OSC_{in} frequencies above 10 MHz.

If unused, the pin should be floated and should be disabled via the C register to minimize dynamic power consumption and electromagnetic interference (EMI).

COUNTER OUTPUT PINS

f_R

R Counter Output (Pin 9)

This signal is the buffered output of the 15-stage R counter. f_R can be enabled or disabled via the C register (patented). The output is disabled (static low logic level) upon power up. If unused, the output should be left disabled and unconnected to minimize interference with external circuitry.

The f_R signal can be used to verify the R counter's divide ratio. This ratio extends from 5 to 32,767 and is determined by the binary value loaded into the R register. Also, direct access to the phase detector via the OSC_{in} pin is allowed by choosing a divide value of 1 (see Figure 15). The maximum frequency which the phase detectors operate is 2 MHz. Therefore, the frequency of f_R must not exceed 2 MHz.

When activated, the f_R signal appears as normally low and pulses high. The pulse width is 4.5 cycles of the OSC_{in} pin signal, except when a divide ratio of 1 is selected. When 1 is

selected, the OSC_{in} signal is buffered and appears at the f_R pin.

f_V

N Counter Output (Pin 10)

This signal is the buffered output of the 16-stage N counter. f_V can be enabled or disabled via the C register (patented). The output is disabled (static low logic level) upon power up. If unused, the output should be left disabled and unconnected to minimize interference with external circuitry.

The f_V signal can be used to verify the N counter's divide ratio. This ratio extends from 40 to 65,535 and is determined by the binary value loaded into the N register. The maximum frequency which the phase detectors operate is 2 MHz. Therefore, the frequency of f_V must not exceed 2 MHz.

When activated, the f_V signal appears as normally low and pulses high.

LOOP PINS

f_{in}

Frequency Input (Pin 4)

This pin is a frequency input from the VCO. This pin feeds the on-chip amplifier which drives the N counter. This signal is normally sourced from an external voltage-controlled oscillator (VCO), and is ac-coupled into f_{in}. A 100 pF coupling capacitor is used for measurement purposes and is the minimum size recommended for applications (see Figure 7). The frequency capability of this input is dependent on the supply voltage as listed in the **Loop Specifications** table. For small divide ratios, the maximum frequency is limited to the divide ratio times 2 MHz. (Reason: the phase/frequency detectors are limited to a maximum frequency of 2 MHz.)

For signals which swing from at least the V_{IL} to V_{IH} levels listed in the **Electrical Characteristics** table, dc coupling may be used. Also, for low frequency signals (less than the minimum frequencies shown in the **Loop Specifications** table), dc coupling is a requirement. The N counter is a static counter and may be operated down to dc. However, wave shaping by a CMOS buffer may be required to ensure fast rise and fall times into the f_{in} pin. See Figure 22.

Each rising edge on the f_{in} pin causes the N counter to decrement by 1.

PD_{out}

Single-Ended Phase/Frequency Detector Output (Pin 13)

This is a three-state output for use as a loop error signal when combined with an external low-pass filter. Through use of a Motorola patented technique, the detector's dead zone has been eliminated. Therefore, the phase/frequency detector is characterized by a linear transfer function. The operation of the phase/frequency detector is described below and is shown in Figure 17.

POL bit (C7) in the C register = low (see Figure 14)

Frequency of f_V > f_R or Phase of f_V Leading f_R: negative pulses from high impedance

Frequency of f_V < f_R or Phase of f_V Lagging f_R: positive pulses from high impedance

Frequency and Phase of f_V = f_R: essentially high-impedance state; voltage at pin determined by loop filter

POL bit (C7) = high

Frequency of $f_V > f_R$ or Phase of f_V Leading f_R : positive pulses from high impedance

Frequency of $f_V < f_R$ or Phase of f_V Lagging f_R : negative pulses from high impedance

Frequency and Phase of $f_V = f_R$: essentially high-impedance state; voltage at pin determined by loop filter

This output can be enabled, disabled, and inverted via the C register. If desired, PD_{out} can be forced to the high-impedance state by utilization of the disable feature in the C register (patented).

ϕ_R and ϕ_V

Double-Ended Phase/Frequency Detector Outputs (Pins 14, 15)

These outputs can be combined externally to generate a loop error signal. Through use of a Motorola patented technique, the detector's dead zone has been eliminated. Therefore, the phase/frequency detector is characterized by a linear transfer function. The operation of the phase/frequency detector is described below and is shown in Figure 17.

POL bit (C7) in the C register = low (see Figure 14)

Frequency of $f_V > f_R$ or Phase of f_V Leading f_R : $\phi_V =$ negative pulses, $\phi_R =$ essentially high

Frequency of $f_V < f_R$ or Phase of f_V Lagging f_R : $\phi_V =$ essentially high, $\phi_R =$ negative pulses

Frequency and Phase of $f_V = f_R$: ϕ_V and ϕ_R remain essentially high, except for a small minimum time period when both pulse low in phase

POL bit (C7) = high

Frequency of $f_V > f_R$ or Phase of f_V Leading f_R : $\phi_R =$ negative pulses, $\phi_V =$ essentially high

Frequency of $f_V < f_R$ or Phase of f_V Lagging f_R : $\phi_R =$ essentially high, $\phi_V =$ negative pulses

Frequency and Phase of $f_V = f_R$: ϕ_V and ϕ_R remain essentially high, except for a small minimum time period when both pulse low in phase

These outputs can be enabled, disabled, and interchanged via the C register (patented).

LD

Lock Detector Output (Pin 11)

This output is essentially at a high level with narrow low-going pulses when the loop is locked (f_R and f_V of the same phase and frequency). The output pulses low when f_V and f_R are out of phase or different frequencies (see Figure 17).

This output can be enabled and disabled via the C register (patented). Upon power up, on-chip initialization circuitry disables LD to a static low logic level to prevent a false "lock" signal. If unused, LD should be disabled and left open.

POWER SUPPLY

V_{DD}

Most Positive Supply Potential (Pin 16)

This pin may range from 2.7 to 5.5 V with respect to V_{SS} . For optimum performance, V_{DD} should be bypassed to V_{SS} using low-inductance capacitor(s) mounted very close to the device. Lead lengths on the capacitor(s) should be minimized. (The very fast switching speed of the device causes current spikes on the power leads.)

V_{SS}

Most Negative Supply Potential (Pin 12)

This pin is usually ground. For measurement purposes, the V_{SS} pin is tied to a ground plane.

Figure 13. Reset Sequence

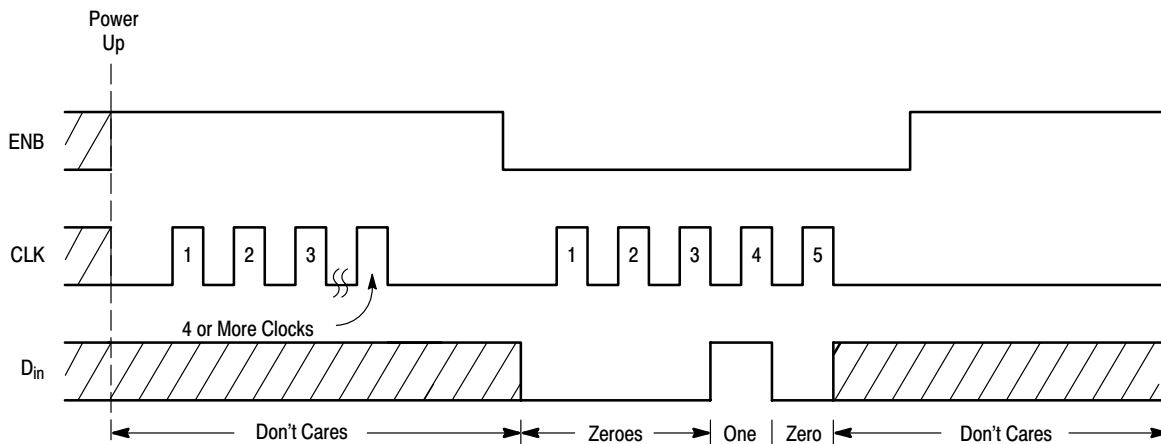

NOTE: This initialization sequence is usually not necessary because the on-chip power-on reset circuit performs the initialization function. However, this initialization sequence must be used immediately after power up if control of the CLK pin is not possible. That is, if CLK (Pin 7) toggles or floats upon power up, use the above sequence to reset the device. Also, use this sequence if power is momentarily interrupted such that the supply voltage to the device is reduced to below 2.7 V, but not down to at least 1 V (for example, the supply drops down to 2 V). This is necessary because the on-chip power-on reset is only activated when the supply ramps up from a voltage below approximately 1.0 V.

Figure 14. C Register Access and Format (8 Clock Cycles are Used)

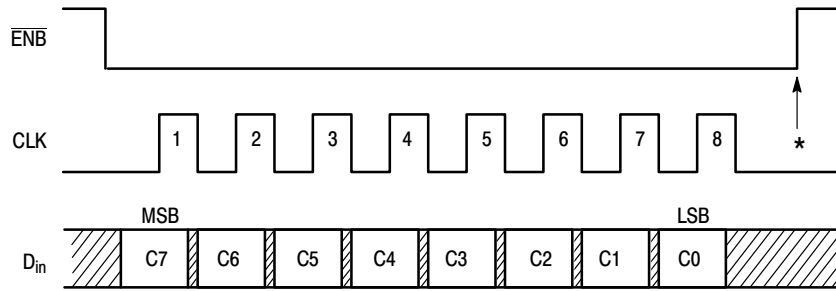

* At this point, the new byte is transferred to the C register and stored. No other registers are affected.

- C7 — POL: Selects the output polarity of the phase/frequency detectors. When set high, this bit inverts PD_{out} and interchanges the ϕ_R function with ϕ_V as depicted in Figure 17. Also see the phase detector output pin descriptions for more information. This bit is cleared low at power up.
- C6 — PDA/B: Selects which phase/frequency detector is to be used. When set high, enables the output of phase/frequency detector A (PD_{out}) and disables phase/frequency detector B by forcing ϕ_R and ϕ_V to the static high state. When cleared low, phase/frequency detector B is enabled (ϕ_R and ϕ_V) and phase/frequency detector A is disabled with PD_{out} forced to the high-impedance state. This bit is cleared low at power up.
- C5 — LDE: Enables the lock detector output when set high. When the bit is cleared low, the LD output is forced to a static low level. This bit is cleared low at power up.
- C4 – C2, OSC2 – OSC0: Reference output controls which determine the REF_{out} characteristics as shown below. Upon power up, the bits are initialized such that OSC_{in}/8 is selected.

C4	C3	C2	REF _{out} Frequency
0	0	0	dc (Static Low)
0	0	1	OSC _{in}
0	1	0	OSC _{in} /2
0	1	1	OSC _{in} /4
1	0	0	OSC _{in} /8 (POR Default)
1	0	1	OSC _{in} /16
1	1	0	OSC _{in} /8
1	1	1	OSC _{in} /16

- C1 — f_VE: Enables the f_V output when set high. When cleared low, the f_V output is forced to a static low level. The bit is cleared low upon power up.
- C0 — f_RE: Enables the f_R output when set high. When cleared low, the f_R output is forced to a static low level. The bit is cleared low upon power up.

MC145170-2

Figure 16. N Register Access and Format (16 Clock Cycles Are Used)

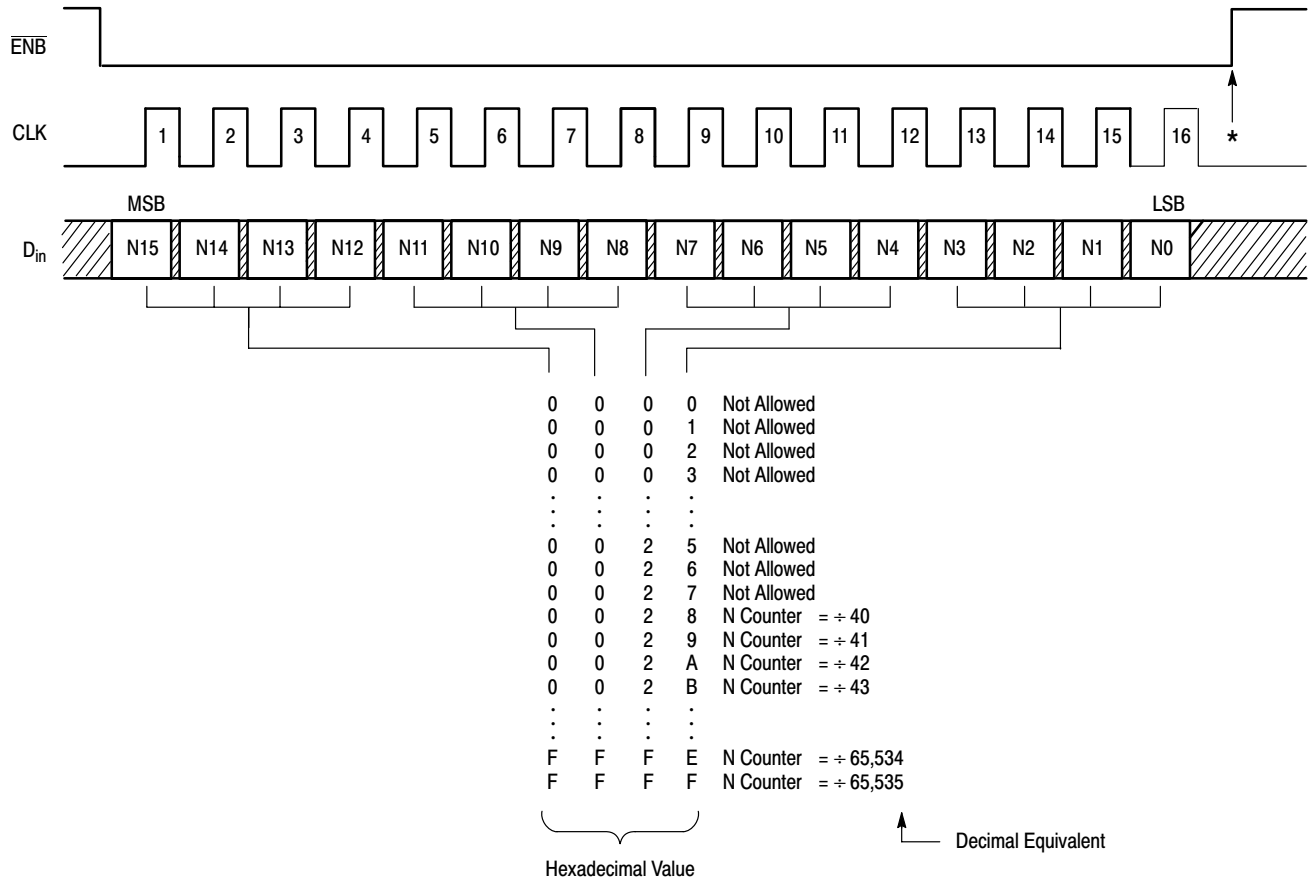

* At this point, the two new bytes are transferred to the N register and stored. No other registers are affected. In addition, the N and R counters are jam-loaded and begin counting down together.

Figure 17. Phase/Frequency Detectors and Lock Detector Output Waveforms

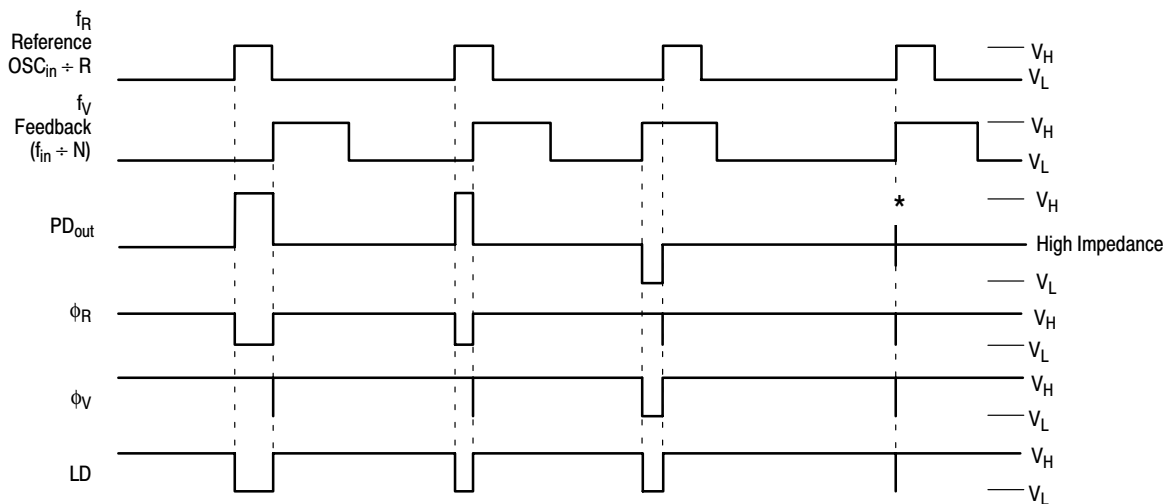

V_H = High voltage level

V_L = Low voltage level

*At this point, when both f_R and f_V are in phase, both the sinking and sourcing output FETs are turned on for a very short interval.

NOTE: The PD_{out} generates error pulses during out-of-lock conditions. When locked in phase and frequency, the output is high impedance and the voltage at that pin is determined by the low-pass filter capacitor. PD_{out} , ϕ_R , and ϕ_V are shown with the polarity bit (POL) = low; see Figure 14 for POL.

MC145170-2

DESIGN CONSIDERATIONS

CRYSTAL OSCILLATOR CONSIDERATIONS

The following options may be considered to provide a reference frequency to Motorola's CMOS frequency synthesizers.

Use of a Hybrid Crystal Oscillator

Commercially available temperature-compensated crystal oscillators (TCXOs) or crystal-controlled data clock oscillators provide very stable reference frequencies. An oscillator capable of CMOS logic levels at the output may be direct or dc coupled to OSC_{in}. If the oscillator does not have CMOS logic levels on the outputs, capacitive or ac coupling to OSC_{in} may be used (see Figures 8a and 8b).

For additional information about TCXOs, visit motorola.com on the world wide web.

Use of the On-Chip Oscillator Circuitry

The on-chip amplifier (a digital inverter) along with an appropriate crystal may be used to provide a reference source frequency. A fundamental mode crystal, parallel resonant at the desired operating frequency, should be connected as shown in Figure 18.

The crystal should be specified for a loading capacitance (C_L) which does not exceed 20 pF when used at the highest operating frequencies listed in the **Loop Specifications** table. Larger C_L values are possible for lower frequencies. Assuming R1 = 0 Ω, the shunt load capacitance (C_L) presented across the crystal can be estimated to be:

$$C_L = \frac{C_{in}C_{out}}{C_{in} + C_{out}} + C_a + C_{stray} + \frac{C1 \times C2}{C1 + C2}$$

where

C_{in} = 5.0 pF (see Figure 19)

C_{out} = 6.0 pF (see Figure 19)

C_a = 1.0 pF (see Figure 19)

C1 and C2 = external capacitors (see Figure 18)

C_{stray} = the total equivalent external circuit stray capacitance appearing across the crystal terminals

The oscillator can be "trimmed" on-frequency by making a portion or all of C1 variable. The crystal and associated components must be located as close as possible to the OSC_{in} and OSC_{out} pins to minimize distortion, stray capacitance, stray inductance, and startup stabilization time. Circuit stray capacitance can also be handled by adding the appropriate stray value to the values for C_{in} and C_{out}. For this approach, the term C_{stray} becomes 0 in the above expression for C_L.

A good design practice is to pick a small value for C1, such as 5 to 10 pF. Next, C2 is calculated. C1 < C2 results in a more robust circuit for start-up and is more tolerant of crystal parameter variations.

Power is dissipated in the effective series resistance of the crystal, R_e, in Figure 20. The maximum drive level specified by the crystal manufacturer represents the maximum stress that the crystal can withstand without damage or excessive shift in operating frequency. R1 in Figure 18 limits the drive level. The use of R1 is not necessary in most cases.

To verify that the maximum dc supply voltage does not cause the crystal to be overdriven, monitor the output frequency at the REF_{out} pin (OSC_{out} is not used because loading impacts the oscillator). The frequency should increase very slightly as the dc supply voltage is increased. An overdriven crystal decreases in frequency or becomes unstable with an increase in supply voltage. The operating supply voltage must be reduced or R1 must be increased in value if the overdriven condition exists. The user should note that the oscillator start-up time is proportional to the value of R1.

Through the process of supplying crystals for use with CMOS inverters, many crystal manufacturers have developed expertise in CMOS oscillator design with crystals. Discussions with such manufacturers can prove very helpful (see Table 2).

Figure 18. Pierce Crystal Oscillator Circuit

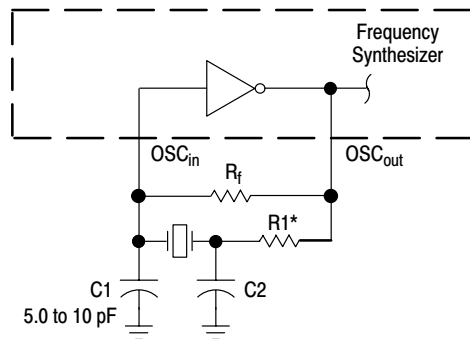

* May be needed in certain cases. See text.

Figure 19. Parasitic Capacitances of the Amplifier and C_{stray}

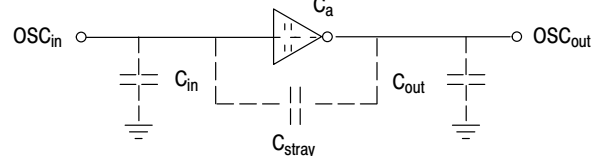
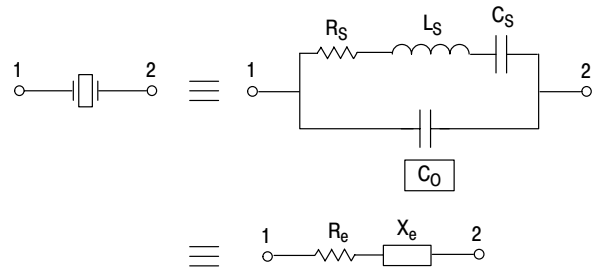

Figure 20. Equivalent Crystal Networks



NOTE: Values are supplied by crystal manufacturer (parallel resonant crystal).

MC145170-2

RECOMMENDED READING

Technical Note TN-24, Statek Corp.

Technical Note TN-7, Statek Corp.

E. Hafner, "The Piezoelectric Crystal Unit-Definitions and Method of Measurement", *Proc. IEEE*, Vol. 57, No. 2, Feb. 1969.

D. Kemper, L. Rosine, "Quartz Crystals for Frequency Control", *Electro-Technology*, June 1969.

P. J. Ottowitz, "A Guide to Crystal Selection", *Electronic Design*, May 1966.

D. Babin, "Designing Crystal Oscillators", *Machine Design*, March 7, 1985.

D. Babin, "Guidelines for Crystal Oscillator Design", *Machine Design*, April 25, 1985.

See web site mot-sps.com for MC145170-2 control software. Select in order, Products, Wireless Semiconductor, Download, then PLL Demo Software. Choose PLLGEN.EXE.

Table 2. Partial List of Crystal Manufacturers

CTS Corp.
United States Crystal Corp.
Crystek Crystal
Statek Corp.
Fox Electronics

NOTE: Motorola cannot recommend one supplier over another and in no way suggests that this is a complete listing of crystal manufacturers.

MC145170-2

PHASE-LOCKED LOOP — LOW PASS FILTER DESIGN

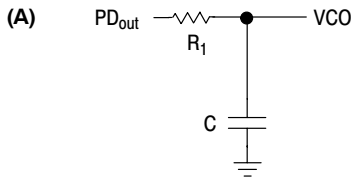

$$\omega_n = \sqrt{\frac{K_\phi K_{VCO}}{NR_1C}}$$

$$\zeta = \frac{N\omega_n}{2K_\phi K_{VCO}}$$

$$F(s) = \frac{1}{R_1sC + 1}$$

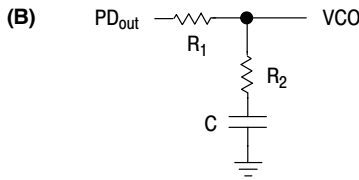

$$\omega_n = \sqrt{\frac{K_\phi K_{VCO}}{NC(R_1 + R_2)}}$$

$$\zeta = 0.5 \omega_n \left(R_2C + \frac{N}{K_\phi K_{VCO}} \right)$$

$$F(s) = \frac{R_2sC + 1}{(R_1 + R_2)sC + 1}$$

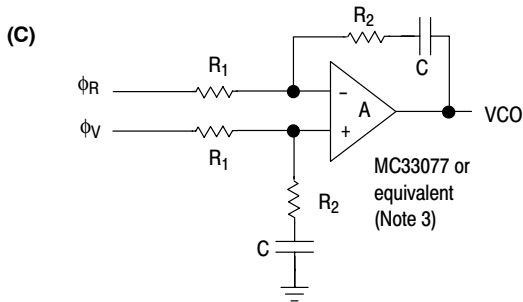

$$\omega_n = \sqrt{\frac{K_\phi K_{VCO}}{NCR_1}}$$

$$\zeta = \frac{\omega_n R_2 C}{2}$$

Assuming Gain A Is Very Large, Then:

$$F(s) = \frac{R_2sC + 1}{R_1sC}$$

NOTES:

- For (C), R_1 is frequently split into two series resistors; each resistor is equal to R_1 divided by 2. A capacitor C_C is then placed from the midpoint to ground to further filter the error pulses. The value of C_C should be such that the corner frequency of this network does not significantly affect ω_n .
- The ϕ_R and ϕ_V outputs swing rail-to-rail. Therefore, the user should be careful not to exceed the common mode input range of the op amp.
- For the latest information on MC33077 or equivalent, see the Motorola Analog IC web site at <http://www.mot-sps.com/analog>.

DEFINITIONS:

N = Total Division Ratio in Feedback Loop

K_ϕ (Phase Detector Gain) = $V_{DD}/4\pi$ volts per radian for PD_{out}

K_ϕ (Phase Detector Gain) = $V_{DD}/2\pi$ volts per radian for ϕ_V and ϕ_R

$$K_{VCO} \text{ (VCO Gain)} = \frac{2\pi\Delta f_{VCO}}{\Delta V_{VCO}}$$

For a nominal design starting point, the user might consider a damping factor $\zeta \approx 0.7$ and a natural loop frequency $\omega_n \approx (2\pi f_R/50)$ where f_R is the frequency at the phase detector input. Larger ω_n values result in faster loop lock times and, for similar sideband filtering, higher f_R -related VCO sidebands.

RECOMMENDED READING:

- Gardner, Floyd M., *Phaselock Techniques (second edition)*. New York, Wiley-Interscience, 1979.
- Manassewitsch, Vadim, *Frequency Synthesizers: Theory and Design (second edition)*. New York, Wiley-Interscience, 1980.
- Blanchard, Alain, *Phase-Locked Loops: Application to Coherent Receiver Design*. New York, Wiley-Interscience, 1976.
- Egan, William F., *Frequency Synthesis by Phase Lock*. New York, Wiley-Interscience, 1981.
- Rohde, Ulrich L., *Digital PLL Frequency Synthesizers Theory and Design*. Englewood Cliffs, NJ, Prentice-Hall, 1983.
- Berlin, Howard M., *Design of Phase-Locked Loop Circuits, with Experiments*. Indianapolis, Howard W. Sams and Co., 1978.
- Kinley, Harold, *The PLL Synthesizer Cookbook*. Blue Ridge Summit, PA, Tab Books, 1980.
- Seidman, Arthur H., *Integrated Circuits Applications Handbook*, Chapter 17, pp. 538-586. New York, John Wiley & Sons.
- Fadrhons, Jan, "Design and Analyze PLLs on a Programmable Calculator," *EDN*. March 5, 1980.
- AN535, Phase-Locked Loop Design Fundamentals, Motorola Semiconductor Products, Inc., 1970.
- AR254, Phase-Locked Loop Design Articles, Motorola Semiconductor Products, Inc., Reprinted with permission from *Electronic Design*, 1987.
- AN1207, The MC145170 in Basic HF and VHF Oscillators, Motorola Semiconductor Products, Inc., 1992.
- AN1671, MC145170 PSpice Modeling Kit, Motorola Semiconductor Products, Inc., 1998.

MC145170-2

Figure 21. Example Application

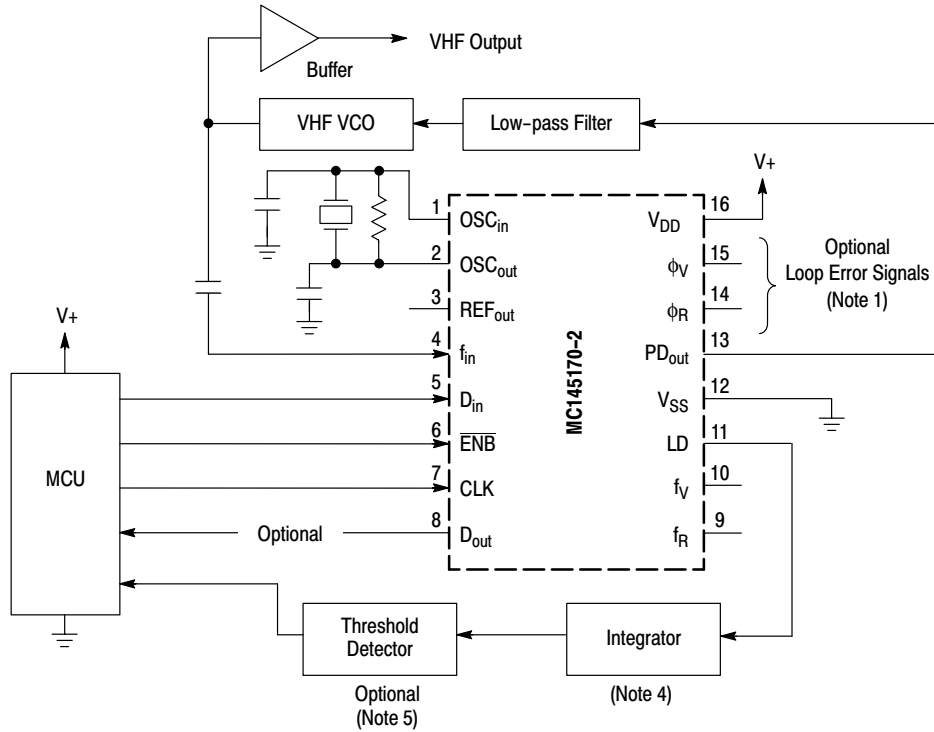

NOTES:

1. The ϕ_R and ϕ_V outputs are fed to an external combiner/loop filter. See the Phase-Locked Loop — Low-Pass Filter Design page for additional information. The ϕ_R and ϕ_V outputs swing rail-to-rail. Therefore, the user should be careful not to exceed the common mode input range of the op amp used in the combiner/loop filter.
2. For optimum performance, bypass the V_{DD} pin to V_{SS} (GND) with one or more low-inductance capacitors.
3. The R counter is programmed for a divide value = OSC_{in}/f_R . Typically, f_R is the tuning resolution required for the VCO. Also, the VCO frequency divided by $f_R = N$, where N is the divide value of the N counter.
4. May be an R-C low-pass filter.
5. May be a bipolar transistor.

MC145170-2

Figure 22. Low Frequency Operation Using dc Coupling

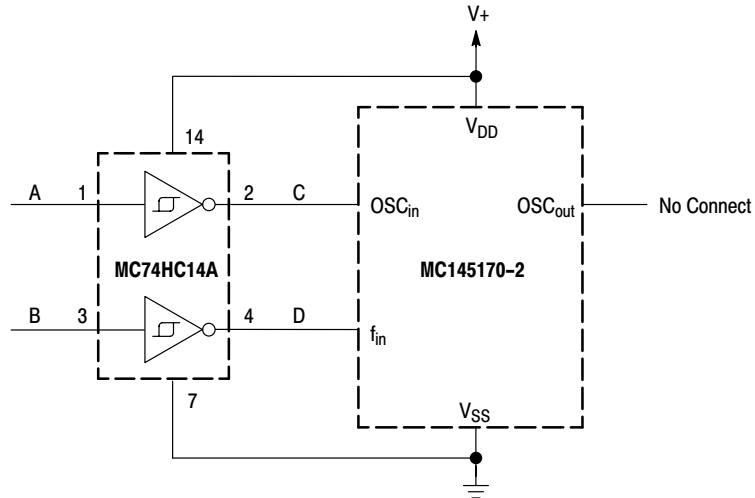

NOTE: The signals at Points A and B may be low-frequency sinusoidal or square waves with slow edge rates or noisy signal edges. At Points C and D, the signals are cleaned up, have sharp edge rates, and rail-to-rail signal swings. With signals as described at Points C and D, the MC145170-2 is guaranteed to operate down to a frequency as low as dc. Refer to the MC74HC14A data sheet for input switching levels and hysteresis voltage range.

MC145170-2

Figure 23. Input Impedance at f_{in} — Series Format ($R + jX$)
(5.0 MHz to 185 MHz)

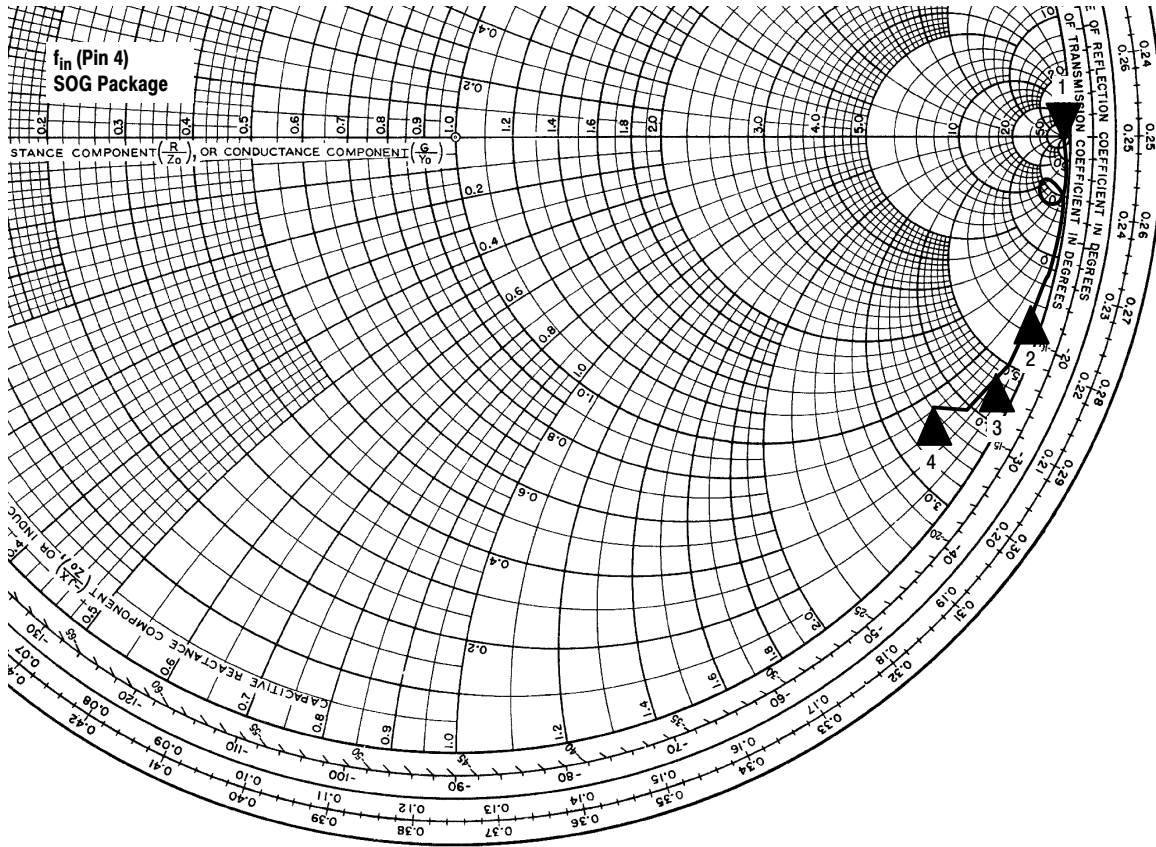

Marker	Frequency (MHz)	Resistance (Ω)	Reactance (Ω)	Capacitance (pF)
1	5	2390	- 5900	5.39
2	100	39.2	- 347	4.58
3	150	25.8	- 237	4.48
4	185	42.6	- 180	4.79

Figure 24. Cascading Two MC145170-2 Devices

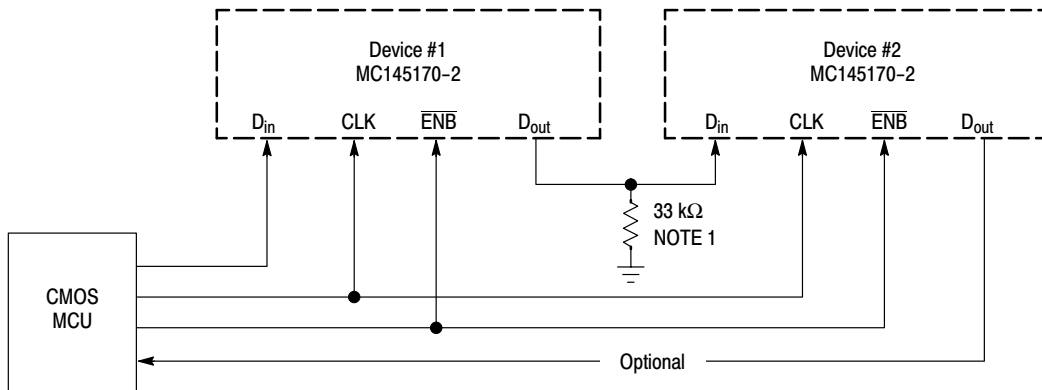

NOTES:

1. The 33 k Ω resistor is needed to prevent the D_{in} pin from floating. (The D_{out} pin is a three-state output.)
2. See related Figures 25, 26, and 27.

Figure 25. Accessing the C Registers of Two Cascaded MC145170-2 Devices

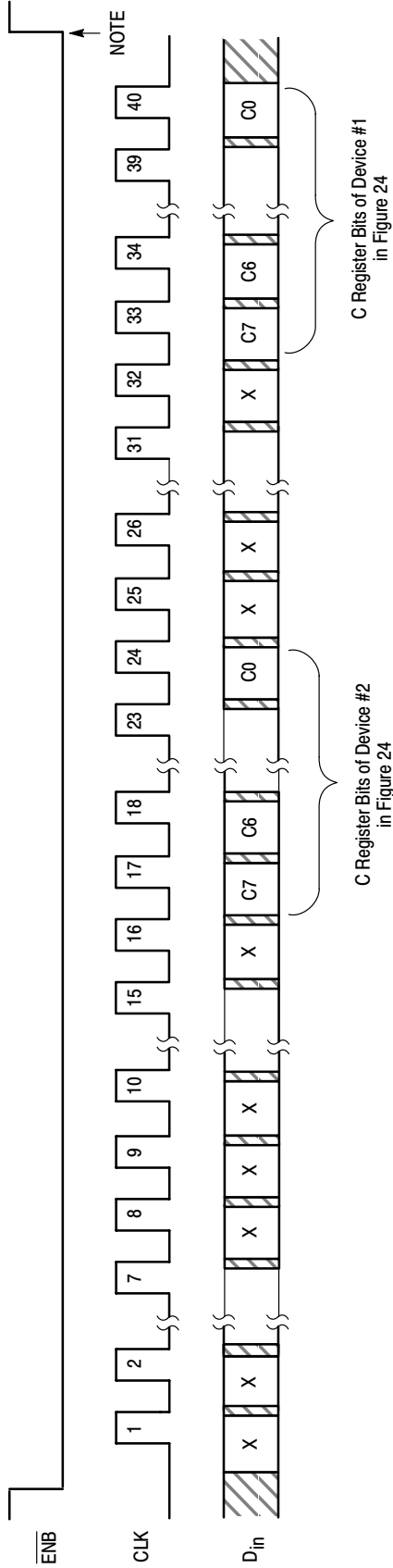

NOTE: At this point, the new data is transferred to the C registers of both devices and stored. No other registers are affected.

Figure 26. Accessing the R Registers of Two Cascaded MC145170-2 Devices

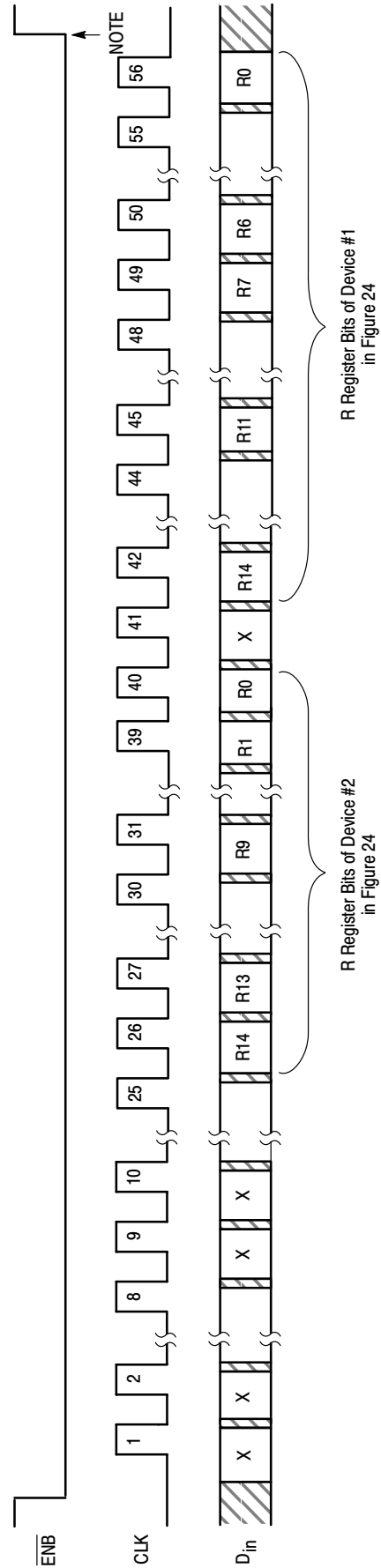

NOTE: At this point, the new data is transferred to the R registers of both devices and stored. No other registers are affected.

Figure 27. Accessing the N Registers of Two Cascaded MC145170-2 Devices

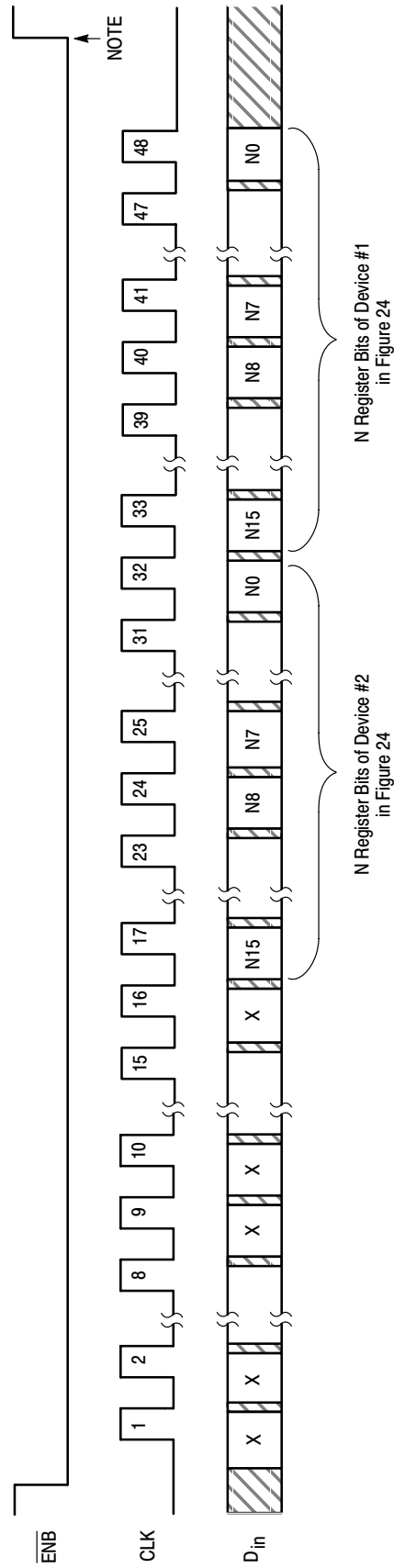

NOTE: At this point, the new data is transferred to the N registers of both devices and stored. No other registers are affected.

MC145170-2

Figure 28. Cascading Two Different Device Types

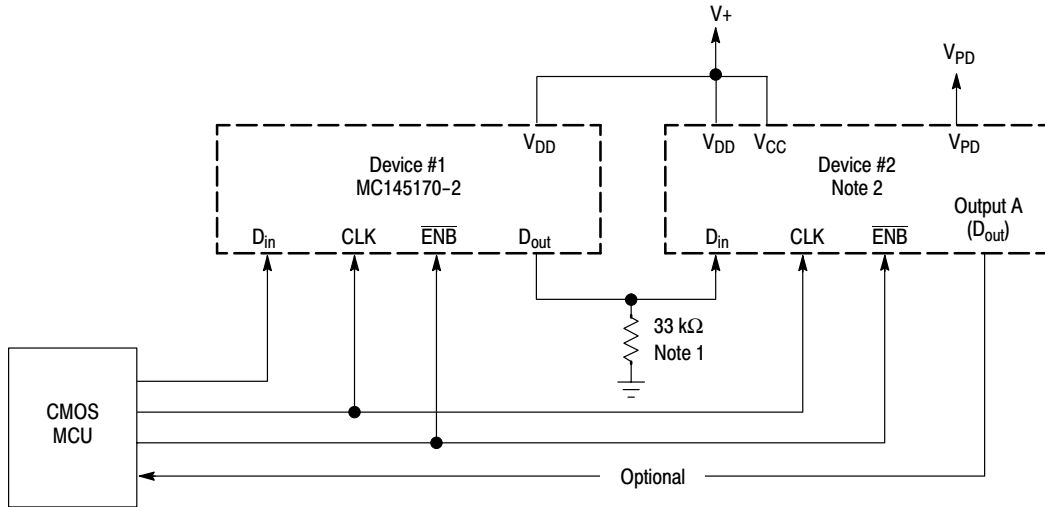

NOTES:

1. The $33\text{ k}\Omega$ resistor is needed to prevent the D_{in} pin from floating. (The D_{out} pin is a three-state output.)
2. This PLL Frequency Synthesizer may be a MC145190, MC145191, MC145192, MC145200, or MC145201.
3. See related Figures 29, 30, and 31.

Figure 31. Accessing the R and N Registers of Two Different Device Types

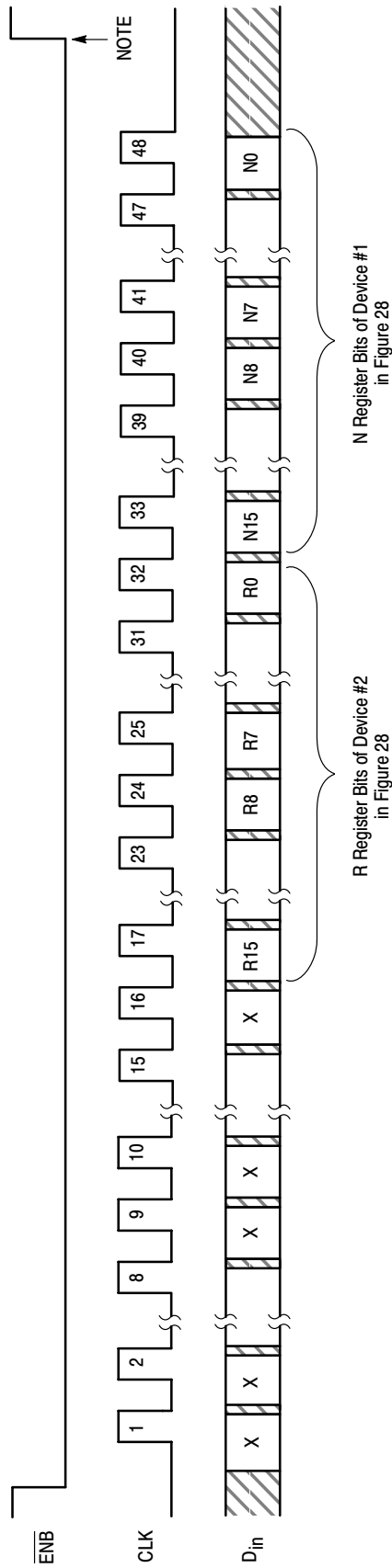

NOTE: At this point, the new data is transferred to the R register of Device #2 and N register of Device #1 and stored. No other registers are affected.

MC145170-2

OUTLINE DIMENSIONS

P SUFFIX PLASTIC PACKAGE CASE 648-08 ISSUE R

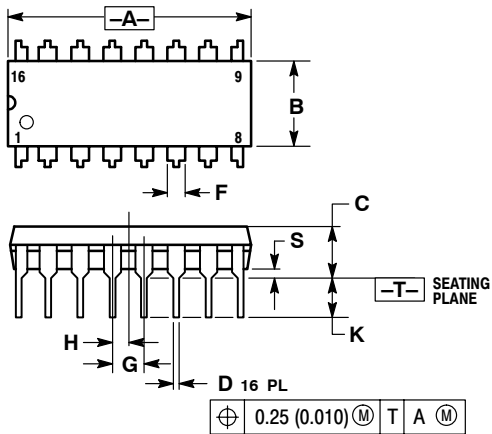

NOTES:

1. DIMENSIONING AND TOLERANCING PER ANSI Y14.5M, 1982.
2. CONTROLLING DIMENSION: INCH.
3. DIMENSION L TO CENTER OF LEADS WHEN FORMED PARALLEL.
4. DIMENSION B DOES NOT INCLUDE MOLD FLASH.
5. ROUNDED CORNERS OPTIONAL.

DIM	INCHES		MILLIMETERS	
	MIN	MAX	MIN	MAX
A	0.740	0.770	18.80	19.55
B	0.250	0.270	6.35	6.85
C	0.145	0.175	3.69	4.44
D	0.015	0.021	0.39	0.53
F	0.040	0.70	1.02	1.77
G	0.100 BSC		2.54 BSC	
H	0.050 BSC		1.27 BSC	
J	0.008	0.015	0.21	0.38
K	0.110	0.130	2.80	3.30
L	0.295	0.305	7.50	7.74
M	0°	10°	0°	10°
S	0.020	0.040	0.51	1.01

D SUFFIX PLASTIC PACKAGE CASE 751B-05 (SOG-16) ISSUE J

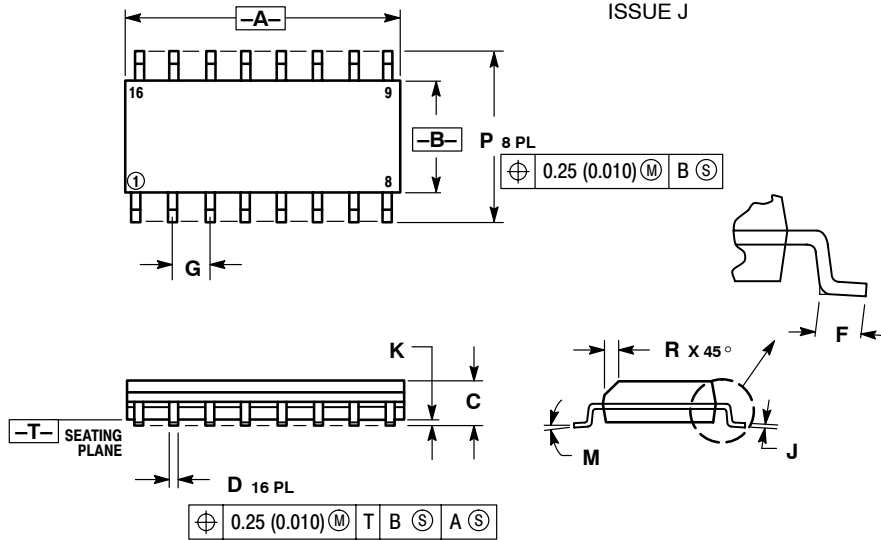

NOTES:

1. DIMENSIONING AND TOLERANCING PER ANSI Y14.5M, 1982.
2. CONTROLLING DIMENSION: MILLIMETER.
3. DIMENSIONS A AND B DO NOT INCLUDE MOLD PROTRUSION.
4. MAXIMUM MOLD PROTRUSION 0.15 (0.006) PER SIDE.
5. DIMENSION D DOES NOT INCLUDE DAMBAR PROTRUSION. ALLOWABLE DAMBAR PROTRUSION SHALL BE 0.127 (0.005) TOTAL IN EXCESS OF THE D DIMENSION AT MAXIMUM MATERIAL CONDITION.

DIM	MILLIMETERS		INCHES	
	MIN	MAX	MIN	MAX
A	9.80	10.00	0.386	0.393
B	3.80	4.00	0.150	0.157
C	1.35	1.75	0.054	0.068
D	0.35	0.49	0.014	0.019
F	0.40	1.25	0.016	0.049
G	1.27 BSC		0.050 BSC	
J	0.19	0.25	0.008	0.009
K	0.10	0.25	0.004	0.009
M	0°	7°	0°	7°
P	5.80	6.20	0.229	0.244
R	0.25	0.50	0.010	0.019

MC145170-2

OUTLINE DIMENSIONS

DT SUFFIX
PLASTIC PACKAGE
CASE 948C-03
(TSSOP-16)
ISSUE B

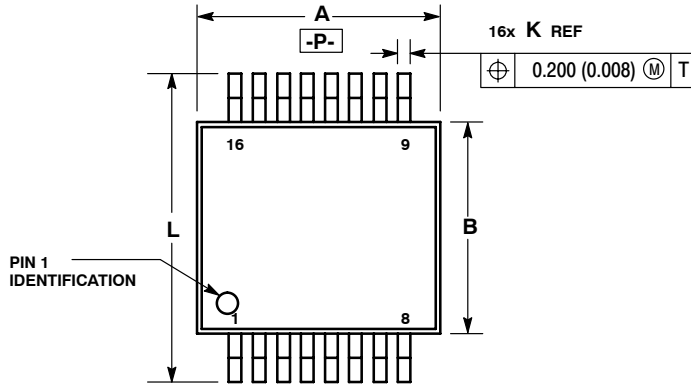

NOTES:

- DIMENSIONING AND TOLERANCING PER ANSI Y14.5M, 1982.
- CONTROLLING DIMENSION: MILLIMETER.
- DIMENSION A DOES NOT INCLUDE MOLD FLASH, PROTRUSIONS OR GATE BURRS. MOLD FLASH OR GATE BURRS SHALL NOT EXCEED 0.15 (0.006) PER SIDE.
- DIMENSION B DOES NOT INCLUDE INTERLEAD FLASH OR PROTRUSION. INTERLEAD FLASH OR PROTRUSION SHALL NOT EXCEED 0.25 (0.010) PER SIDE.
- DIMENSION K DOES NOT INCLUDE DAMBAR PROTRUSION. ALLOWABLE DAMBAR PROTRUSION SHALL BE 0.08 (0.003) TOTAL EXCESS OF THE K DIMENSION AT MAXIMUM MATERIAL CONDITION.
- TERMINAL NUMBERS ARE SHOWN FOR REFERENCE ONLY.
- DIMENSIONS A AND B ARE TO BE DETERMINED AT DATUM PLANE -U-.

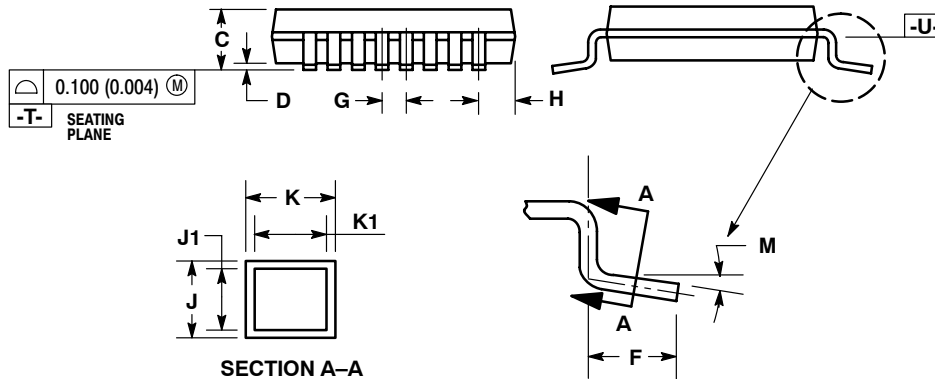

DIM	MILLIMETERS		INCHES	
	MIN	MAX	MIN	MAX
A	---	5.10	---	0.200
B	4.30	4.50	0.169	0.177
C	---	1.20	---	0.047
D	0.05	0.25	0.002	0.010
F	0.45	0.55	0.018	0.022
G	0.65 BSC		0.026 BSC	
H	0.22	0.23	0.009	0.010
J	0.09	0.24	0.004	0.009
J1	0.09	0.18	0.004	0.007
K	0.16	0.32	0.006	0.013
K1	0.16	0.26	0.006	0.010
L	6.30	6.50	0.248	0.256
M	0°	10°	0°	10°

Motorola reserves the right to make changes without further notice to any products herein. Motorola makes no warranty, representation or guarantee regarding the suitability of its products for any particular purpose, nor does Motorola assume any liability arising out of the application or use of any product or circuit, and specifically disclaims any and all liability, including without limitation consequential or incidental damages. "Typical" parameters which may be provided in Motorola data sheets and/or specifications can and do vary in different applications and actual performance may vary over time. All operating parameters, including "Typicals" must be validated for each customer application by customer's technical experts. Motorola does not convey any license under its patent rights nor the rights of others. Motorola products are not designed, intended, or authorized for use as components in systems intended for surgical implant into the body, or other applications intended to support or sustain life, or for any other application in which the failure of the Motorola product could create a situation where personal injury or death may occur. Should Buyer purchase or use Motorola products for any such unintended or unauthorized application, Buyer shall indemnify and hold Motorola and its officers, employees, subsidiaries, affiliates, and distributors harmless against all claims, costs, damages, and expenses, and reasonable attorney fees arising out of, directly or indirectly, any claim of personal injury or death associated with such unintended or unauthorized use, even if such claim alleges that Motorola was negligent regarding the design or manufacture of the part. Motorola, Inc. is an Equal Opportunity/Affirmative Action Employer. MOTOROLA and the logo are registered in the US Patent & Trademark Office. All other product or service names are the property of their respective owners.

© Motorola, Inc. 2002

How to reach us:

USA/EUROPE/Locations Not Listed: Motorola Literature Distribution;
P.O. Box 5405, Denver, Colorado 80217. 1-303-675-2140 or 1-800-441-2447

JAPAN: Motorola Japan Ltd.; SPS, Technical Information Center, 3-20-1,
Minami-Azabu, Minato-ku, Tokyo 106-8573 Japan. 81-3-3440-3569

Technical Information Center: 1-800-521-6274

ASIA/PACIFIC: Motorola Semiconductors H.K. Ltd.; Silicon Harbour Centre,
2, Dai King Street, Tai Po Industrial Estate, Tai Po, N.T., Hong Kong.
852-26668334

HOME PAGE: <http://www.motorola.com/semiconductors/>



This datasheet has been download from:

www.datasheetcatalog.com

Datasheets for electronics components.